



A-Click Backup Manager v7

Office 365 Exchange Online Backup & Restore Guide for Mac OS X

Ahsay Systems Corporation Limited

2 January 2018

Copyright Notice

© 2018 Ahsay Systems Corporation Limited. All rights reserved.

The use and copying of this product is subject to a license agreement. Any other use is prohibited. No part of this publication may be reproduced, transmitted, transcribed, stored in a retrieval system or translated into any language in any form by any means without prior written consent of Ahsay Systems Corporation Limited. Information in this manual is subject to change without notice and does not represent a commitment on the part of the vendor, Ahsay Systems Corporation Limited does not warrant that this document is error free. If you find any errors in this document, please report to Ahsay Systems Corporation Limited in writing.

This product includes software developed by the Apache Software Foundation (<http://www.apache.org/>).

Trademarks

Ahsay, Ahsay Cloud Backup Suite, Ahsay Online Backup Suite, Ahsay Offsite Backup Server, Ahsay Online Backup Manager, Ahsay A-Click Backup, Ahsay Replication Server, Ahsay BackupBox Firmware, Ahsay Universal Backup System, Ahsay NAS Client Utility are trademarks of Ahsay Systems Corporation Limited.

Amazon S3 is registered trademark of Amazon Web Services, Inc. or its affiliates.

Apple and Mac OS X are registered trademarks of Apple Computer, Inc.

Dropbox is registered trademark of Dropbox Inc.

Google Cloud Storage and Google Drive are registered trademarks of Google Inc.

Lotus, Domino, Notes are registered trademark of IBM Corporation.

Microsoft, Windows, Microsoft Exchange Server, Microsoft serverServer, Microsoft Hyper-V, Microsoft Azure, One Drive and One Drive for Business are registered trademarks of Microsoft Corporation.

Oracle and Java are registered trademarks of Oracle and/or its affiliates. Other names may be trademarks of their respective owners.

Oracle, Oracle 10g, Oracle 11g and MySQL are registered trademarks of Oracle Corporation.

Rackspace and OpenStack are registered trademarks of Rackspace US, Inc.

Red Hat, Red Hat Enterprise Linux, the Shadowman logo and JBoss are registered trademarks of Red Hat, Inc. www.redhat.com in the U.S. and other countries. Linux is a registered trademark of Linus Torvalds.

ShadowProtect is registered trademark of StorageCraft Technology Corporation.

VMware, ESX, ESXi, vCenter are registered trademarks of VMware, Inc.

All other product names are registered trademarks of their respective owners.

Disclaimer

Ahsay Systems Corporation Limited will not have or accept any liability, obligation or responsibility whatsoever for any loss, destruction or damage (including without limitation consequential loss, destruction or damage) however arising from or in respect of any use or misuse of reliance on this document. By reading and following the instructions in this document, you agree to accept unconditionally the terms of this Disclaimer and as they may be revised and/or amended from time to time by Ahsay Systems Corporation Limited without prior notice to you.

Revision History

Date	Descriptions	Type of modification
5 Apr 2017	First Draft	New
3 Nov 2017	Added Supported Source for Ch.2.4	New
14 Dec 2017	Updated diagram for System Architecture for Ch1.2; Added and updated items and diagram in Ch.1.3; Added some requirements for Office365 Exchange Online subscription & account for Ch. 2.3; Added Best Practice and Recommendation for Ch.2.6; Updated process flow for Ch.5	New / Modified
2 Jan 2018	Added AhsayACB Licenses, Continuous Backup Module and Java Heap Size requirement for Ch.2.3; Added Screen Shot for Add-on Module for Ch.2.3; Added Public Folder Management permission for user account for Ch.2.3; Added content of backup destination in the comparison table for Ch.1.3; Added Set Backup Destination and Login AhsayACB for Best Practice and Recommendation for Ch.2.6	New / Modified

Table of Contents

1	Overview	1
	What is this software?	1
	System Architecture	1
	Why should I use AhsayACB or AhsayCBS User Web Console?.....	2
	About This Document.....	9
2	Preparing for Backup and Restore	10
	Hardware Requirement	10
	Software Requirement	10
	Other Requirements	10
	Supported Source	15
	Limitation	16
	Best Practices and Recommendations.....	16
3	Login to AhsayACB / AhsayCBS User Web Console	18
	Login to AhsayACB.....	18
	Login to AhsayCBS User Web Console	19
4	Creating an Office 365 Exchange Online Backup Set	20
	Creating a Backup Set on AhsayACB	20
	Create a Backup Set on User Web Console.....	27
5	Overview of Office 365 Exchange Online Backup Process	33
6	Running Backup Job	34
	Start a Manual Backup in AhsayACB	34
	Start a Manual Backup on the User Web Console	35
	Configure Backup Schedule for Automated Backup	37
	Setting up on AhsayACB	37
	Setting on User Web Console.....	39
7	Restoring Office 365 Exchange Online Backup Set	41
	Restore Backup with AhsayACB	41
	Restore Backup with User Web Console.....	43
8	Contacting Ahsay	45
	Technical Assistance	45
	Documentation	45
	Appendix	46
	Appendix A Setting Backup Destination on AhsayACB for Backup Set Created on User Web Console.....	46

1 Overview

What is this software?

Ahsay brings you specialized client backup software, namely AhsayACB, to provide a set of tools to protect your mailbox accounts on Office 365 Exchange Online. This includes backup and recovery of individual emails, contacts, calendars and other mail items in your Office 365 mailboxes, with snapshots / versioning, and retention policy to protect even email that you may have accidentally deleted from your Office 365 mailbox.

System Architecture

Below is the system architecture diagram illustrating the major elements involved in the backup process among the Office 365 Exchange Online service, AhsayACB and AhsayCBS.

In this user guide, we will focus on the software installation, as well as the end-to-end backup and restore process using both AhsayCBS User Web Console (Agentless) and the AhsayACB (Agent-based).

1. **Agentless:** No need to install AhsayACB. The AhsayCBS backup server connects to the Office 365 Exchange online directly through the Internet.

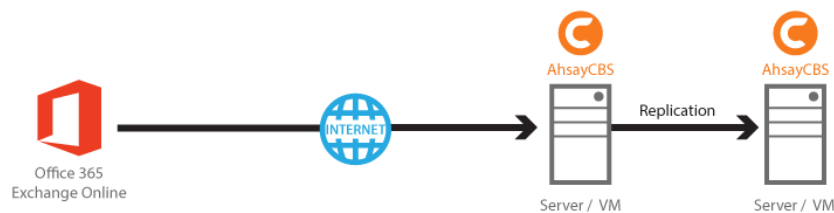

2. **Agent-based:** The latest version of AhsayACB is installed on the remote backup machine which is connected to Office 365 Exchange online and AhsayCBS backup server through internet.

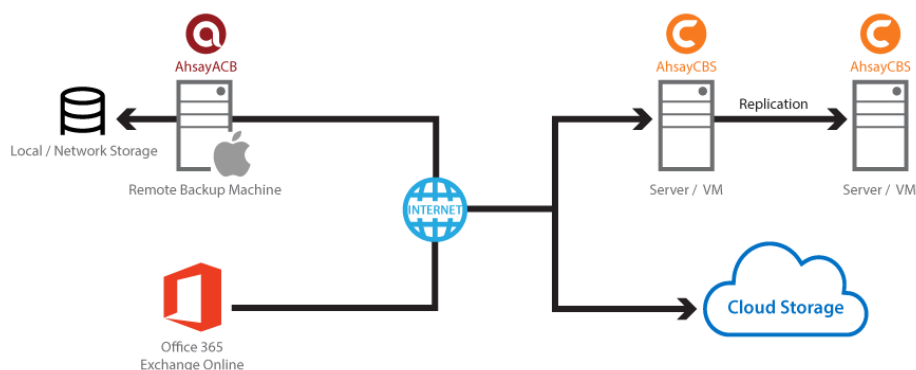

Why should I use AhsayACB or AhsayCBS User Web Console?

We are committed to bringing you a comprehensive Office 365 Exchange Online backup solution with AhsayACB. Below are some key areas that we can help making your backup experience a better one.

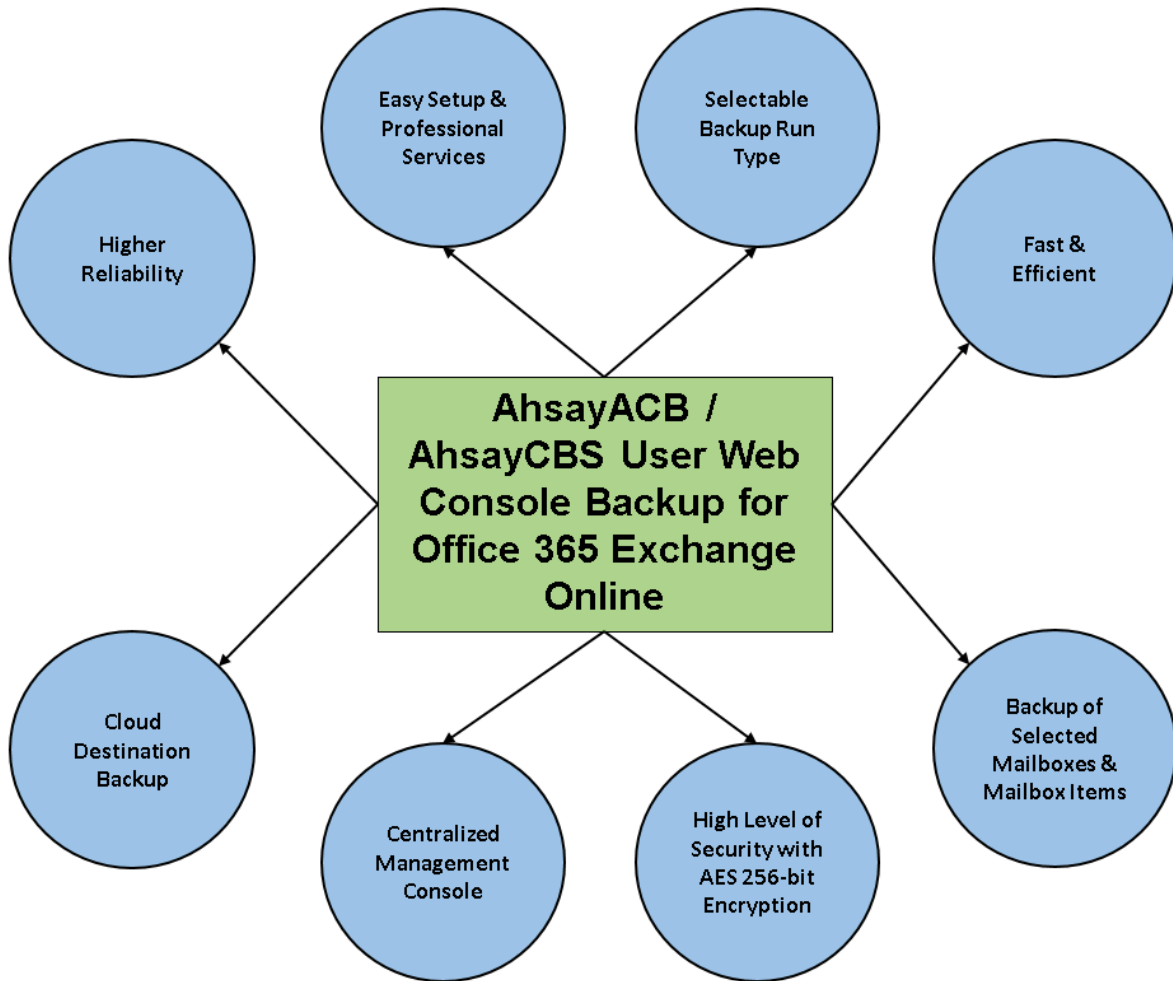

Easy Setup & Professional Services

Setup is a few clicks away - our enhanced AhsayACB v7 can be easily downloaded and installed in just a few clicks. The refined user interface also provides user-friendly instructions to guide you through installation, configuration, backup and restore. The intuitive setup procedures together with instructions in this user guide makes the software installation and operations easy even for layman users. That being said, if you do run into any problems during setup, we are here to help out. Visit the URL below for details on technical assistance.

<https://www.ahsay.com/jsp/en/contact/kbQuestion.jsp>

Professional Services

AhsayACB Installation and Configuration Service

If you would like to save the time of reading through this document for setup, we have introduced this service to take care of all the installation and setup for you. On top of the installation and setup services, we also have a whole series of premium after-sales services to provide you with the best user experiences possible.

Valid Maintenance

Our Valid Maintenance provides you with professional and timely customer support along the way. You are entitled to the Valid Maintenance for free during the first year of your service subscription, and recurring annual fee at 20% of your annual subscription fee.

Refer to our [Professional Services](#) webpage for further details and subscription.

Selectable Backup Run Type

You can choose to either run the backup set you created on Server (AhsayCBS User Web Console) or Client (AhsayACB).

NOTE

The run type of an Office 365 Exchange Online backup set can only be set if you create a backup set via the AhsayCBS Admin / User Web Console. For backup set created via the backup client application (i.e. AhsayACB), the run type is set to Run on Client by default.

Run on Server

A Run on Server Office 365 Exchange Online backup set provides you with an agentless backup solution. Manual or scheduled backup job is performed on the backup server (i.e. AhsayCBS User Web Console); you do not need to install a backup agent on your personal computer in order to backup your data on cloud storages. The advantages of agentless backup technology make it a good option for users who want to simplify the backup and restore management.

Run on Client

A Run on Client Office 365 Exchange Online backup set provides you with an agent-based backup solution. Manual or scheduled backup job is performed on the client computer (i.e. AhsayACB); you need to install a backup agent on your personal computer in order to back up your data on cloud storages. The advantages of agent-based backup technology make it a good option for users who want to have more control on individual backup / restore and resources management.

Comparison between Run on Server and Run on Client

With both **Run on Server** (agentless) and **Run on Client** (agent-based) backup options available and the freedom to use different setting on different backup sets according to your needs, our backup solution offers you with high level of flexibility and efficiency for Office 365 Exchange Online backup and restore.

Below is the comparison between backup and restore job Run on Server and Run on Client.

	Run on Server (AhsayCBS User Web Console)	Run on Client (AhsayACB)
Installation	➤ No need to install the client backup agent on your computer or upgrade it when a newer version becomes available, which can fulfill some regulatory requirements of compliance during backup or	➤ Need to install the latest version of AhsayACB on computer with internet access for connection to Office 365 account.

	<p>restore.</p> <ul style="list-style-type: none"> ➤ Only a web browser and internet connection is needed. 	
Backup	<ul style="list-style-type: none"> ➤ Backup operation of all users are performed on the backup server, which means multiple jobs may run at the same time leading to slower performance. ➤ Backup period will be shorter as the backup data are transferred directly from Office 365 Exchange Online to AhsayCBS backup server. ➤ Backup destination is restricted to AhsayCBS backup server. 	<ul style="list-style-type: none"> ➤ Backup job is performed on your computer with resources that is dedicated to yourself. ➤ In the event of a failure to a single backup agent, it fails in isolation to other users' environment. ➤ Backup period will be longer as the backup data are transferred from Office 365 Exchange Online to AhsayACB, then to AhsayCBS backup server. ➤ Backup destination can be AhsayCBS backup server, local and cloud drive and FTP.
Large Number of Mailbox Backup Sets	<ul style="list-style-type: none"> ➤ Backup of large number of mailbox backup set may take more time. As it will increase the AhsayCBS server load a lot if run multiple mailbox backup sets concurrently and may affect the server performance, so it will make backup speed slower and period longer. 	<ul style="list-style-type: none"> ➤ Backup of large number of mailbox backup sets may take less time. As backup sets can be run concurrently over several machines as distributed solution, the resource will be more and will make backup speed faster and period shorter.
Cost	<ul style="list-style-type: none"> ➤ Do not require provision of additional Mac machine. 	<ul style="list-style-type: none"> ➤ May require the provision of an additional Mac machine.
Restore	<ul style="list-style-type: none"> ➤ Restore operation of all users are performed on the backup server which may have multiple jobs to run at the same time, resulting in slower performance. ➤ Restore period should be shorter as the backed up items are transferred directly from AhsayCBS backup server to Office 365 Exchange Online. 	<ul style="list-style-type: none"> ➤ Restore job is performed on your computer with resources that is dedicated to yourself. ➤ In the event of a failure to a single backup agent, it fails in isolation to other users' environment. ➤ Restore period should be longer as the backed up items are transferred from AhsayCBS backup server to AhsayACB first and then to Office 365 Exchange Online.

Differences between a Run on Server and Run on Client Backup Set

The following table summarizes the differences in backup options available for a Run on Server or Run on Client, and the tool to use (client agent or user web console) when performing a backup and restore:

	Run on Server Office 365 Exchange Online Backup Set	Run on Client Office 365 Exchange Online Backup Set
General Settings	Yes	Yes
Backup Source	Yes	Yes
Backup Schedule	Yes	Yes
Continuous Backup	Yes	Yes
Destination	Yes (Restricted to AhsayCBS only)	Yes
In-File Delta	Yes	Yes
Retention Policy	Yes	Yes
Command Line Tool	N/A	Yes
Reminder	N/A	N/A
Bandwidth Control	Yes	Yes
IP Allowed for Restore	N/A	N/A
Other	Yes	Yes
To Run a Backup	AhsayCBS User Web Console Only	AhsayACB / AhsayCBS
To Run a Restore	AhsayCBS User Web Console Only	AhsayACB / AhsayCBS

Fast and Efficient

We understand that backup could be a time and resources consuming process, which is why AhsayACB is designed with advanced technologies to make backup a fast and efficient process.

We also understand that you may wish to run backup at a specified time interval of your choice, that's why we also allow you to set your own backup schedules so that you can take full control of the time when to perform backup.

- ▶ **Multi-threading** – this technology utilizes the computing power of multiple CPU cores for creating multiple backup and restore threads to produce fast backup and restore performance.

The default setting for Office 365 Exchange Online backup sets supports

- ◉ Backup of 4 mailboxes concurrently (4 threads).
- ◉ For each of the 4 mailboxes, now supports a maximum 4 mail items concurrently (4 threads).

For Agentless Option:

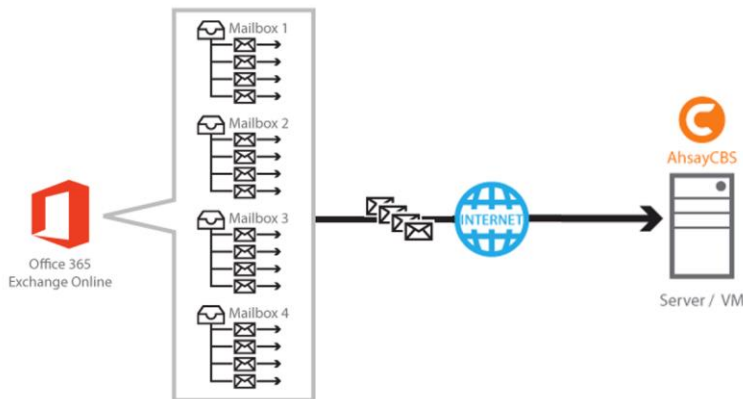

For Agent-based Option:

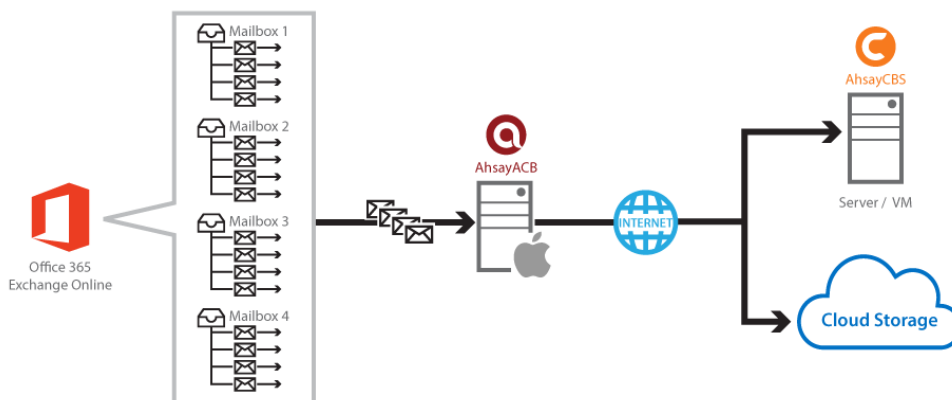

As shown the technology translate into a total of 16 concurrent threads.

- **Index File Structure** – The index file structure has been re-designed to improve the backup and restore performance.

Each Office 365 Exchange online mailbox will have its own individual index file instead of a single index file for all mailboxes within the backup set.

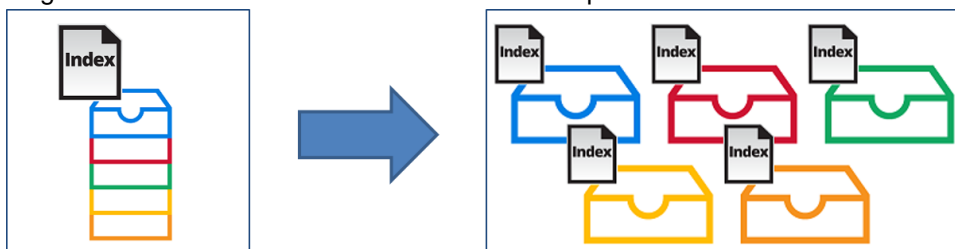

This new design eliminates any potential I/O performance bottlenecks when the index files are updated during each backup job, which can occur when using single index file structure for multi-thread concurrent backup.

- **Block Level Incremental Backup** – this technology breaks down the backup files into multiple blocks and only the changed blocks will be backed up each time.

Backup of Selected Mailboxes & Mailbox Items

The backup resources can be mailbox level, folder level and even item level.

- Flexible backup options:
 - Only select the required mailboxes, specific folders or items for backup.
- Flexible restore options:
 - Restore the whole mailbox contents or just one email.
 - Restore mail items to the original mailbox or an alternate mailbox

High Level of Security

We understand your Office 365 mail objects may contain sensitive information that requires to be protected, that is why your backup data will be encrypted with the highest level of security measure.

- **Un-hackable Encryption Key** – to provide the best protection to your backup data, you can turn on the encryption feature which will be default encrypt the backup data locally with AES 256-bit truly randomized encryption key.
- **Encryption Key Recovery** – Furthermore, we have a backup plan for you to recover your encryption key in case you have lost it. You backup service provider can make it mandatory for you to upload the encryption key to the centralized management console, the encryption key will be uploaded in hashed format and will only be used when you request for a recovery.

Centralized Management Console

Our enriched features on the centralized web console offers you a one-stop location for monitoring and managing your backup and restore. Below is an overview of what you can do with it. For more details regarding the setup and operations of the centralized management console, refer to the [AhsayCBS Administrator's Guide](#) for details.

- Create/ update/ delete backup set
- Restore backup
- Configure user settings
- Configure backup settings
- View and download backup and restore reports
- Monitor backup and restore live activities
- Monitor storage statistic

Cloud Destinations Backup

To offer you with the highest flexibility of backup destination, you can now back up mail objects to a wide range of cloud storage destinations. Utilizing cloud destination backup gives you an extra layer of protection in the event of a local drive corruption, where you will still be able to retrieve data from the cloud destination.

NOTE

Cloud destination backup applies only to agent-based backup sets. The backup destination is restricted to AhsayCBS for all agentless backup sets.

Below is a list of supported cloud destinations.

Aliyun (阿里云) *	Google Drive	Amazon S3	Amazon Cloud Drive
Google Cloud Storage	CTYun (中国电信天翼云)*	AWS S3 Compatible Cloud Storage	Microsoft OneDrive / OneDrive for Business
Rackspace	OpenStack	Microsoft Azure	Dropbox
FTP	SFTP	OneDrive	

Higher Reliability

The implementation of one index file per mailbox can significantly improve the overall resilience of backup and restore from index related issues.

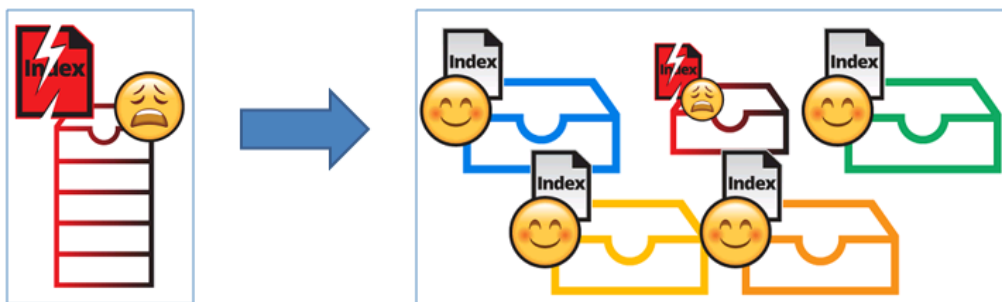

For example, if a single index file corrupted, it will only affect corresponding mailbox, while other mailboxes selected for backup are unaffected.

About This Document

What is the purpose of this document?

This document aims at providing all necessary information for you to get started with setting up your system for Office 365 Exchange Online backup and restore, followed by step-by-step instructions on creating backup set, running backup job and restoring backed up data, using both the AhsayACB and AhsayCBS Web User Console.

The document can be divided into 3 main parts.

Part 1: Preparing for Office 365 Exchange Online Backup & Restore

Requirements

Requirements on hardware & software for installation

Best Practices and Recommendations

Items recommended to pay attention to before backup and restore

Part 2: Performing Office 365 Exchange Online Backup

Logging in to Client Agent or User Web Console

Log in to AhsayACB or User Web Console

Creating a Backup Set

Create a backup set using AhsayACB and User Web Console

Running a Backup Set

Run a backup set using the AhsayACB and User Web Console

Configuring an Automated Backup

Configure backup schedule for automated backup

Part 3: Restoring Office 365 Exchange Online Backup

Restoring a Backup Set using AhsayACB & User Web Console

Restore a backup using the AhsayACB and User Web Console

What should I expect from this document?

After reading through this documentation, you can expect to have sufficient knowledge to set up your system to backup Office 365 Exchange Online on AhsayACB, as well as to carry out an end-to-end backup and restore process.

Who should read this document?

This documentation is intended for backup administrators and IT professionals who are responsible for the Office 365 Exchange Online backup and restore.

2 Preparing for Backup and Restore

Hardware Requirement

To achieve the optimal performance when AhsayACB is running on your machine, refer to the following article for the list of hardware requirements.

[FAQ: Ahsay Hardware Requirement List \(HRL\) for version 7.3 or above](#)

Software Requirement

Make sure the operating system where you have the Office 365 Exchange Online installed is compatible with the AhsayACB. Refer to the following article for the list of compatible operating systems and application versions.

[FAQ: Ahsay Software Compatibility List \(SCL\) for version 7.3 or above](#)

Other Requirements

• AhsayACB Installation

Office 365 Exchange Online backup for AhsayACB is supported from v7.11.0.0. Make sure that the latest version of AhsayACB is installed on your computer with Internet access for connection to your Office 365 Exchange online account.

User should also stay up-to-date when newer version of AhsayACB is released. To get our latest product and company news through email, please subscribe to our mailing list. http://www.ahsay.com/jsp/en/home/subscribe_mail_list.jsp

• Add-on Module Requirement

One Office 365 Exchange Online Backup license is required for the backup of each user mailbox. No license is required for public folder.

Make sure that the Office 365 Exchange Online Backup add-on module is enabled for your AhsayACB user account, and sufficient mailbox quota is assigned.

NOTE

Please be reminded that a maximum of two modules is allowed for Office 365 Exchange Online Backup on AhsayACB. If you wish to add extra module, consider using AhsayOBM instead. Contact your backup service provider for more details.

The screenshot shows the 'User Profile' settings page for a user. The 'Backup Client Settings' tab is active. Under 'Backup Client', 'AhsayACB User' is selected. Under 'Add-on Modules', 'Office 365 Exchange Online Backup' is checked and set to '2'. Other modules like 'Windows System Backup', 'Volume Shadow Copy', and 'In-File Delta' are unchecked.

▶ **Access for AhsayCBS User Web Console**

It is now possible to perform agentless backup and restore, which can be done via the AhsayCBS User Web Console without using the AhsayACB client agent. In order to access the User Web Console, make sure you have Internet connection and a web browser installed on your computer or mobile device.

▶ **AhsayACB Licenses**

AhsayACB licenses are calculated on a per device basis:

- i. To backup mailboxes with 1 backup client computer / Exchange server (e.g. 1 AhsayACB installed), 1 AhsayACB license is required.
- ii. To backup mailboxes with multiple backup client computers, the number of AhsayACB licenses required is equal to the number of devices. For example, if there are 2 mailboxes to be backup with 3 backup client computers, then 3 AhsayACB licenses are required.

Please contact your backup service provider for more details.

▶ **Backup Quota Requirement**

Make sure that your AhsayACB user account has sufficient quota assigned to accommodate the storage of the Office 365 Exchange Online mailboxes and public folder items for the new backup set and retention policy.

Please contact your backup service provider for details.

▶ **Continuous Backup Module**

The Continuous backup add-on module is required if you would like to enable the continuous backup feature.

▶ **Java Heap Size**

The default Java heap size setting on AhsayACB is 2048MB. For Office 365 Exchange online backup, it is highly recommended to increase the Java heap size setting to at least 4096MB to improve backup and restore performance. The actual heap size is dependent on amount of free memory available on the machine with AhsayACB installed (machine that is running the backup).

▶ **Office 365 Subscription Plan**

The following subscription plans with Exchange Online email services are supported to run backup and restore on AhsayACB or AhsayCBS User Web Console.

Office 365 Business Essentials	Office 365 Business Premium
Office 365 Education	Office 365 Enterprise E1
Office 365 Enterprise E3	Office 365 Enterprise E4
Office 365 Enterprise E5	

▶ **Office 365 Subscription Status**

Make sure your Office 365 Exchange Online subscription with Microsoft is active in order to enjoy all privileges that come along with our backup services. If your account

has expired, renew it with Microsoft as soon as possible so that you can continue enjoy the Office 365 Exchange Online backup services provided by Ahsay.

When your account is expired, depending on your role, certain access restrictions will be applied to your account. Refer to the URL below for more details.

[Microsoft Office 365 Subscription Status](#)

❶ Granting Permission to Accounts for Creating Backup Set

Before the Office 365 account administrator or other accounts can create a backup set, the administrator has to grant permission to the account(s) which are going to create backup set. The account must be a member of the following security groups:

- Discovery Management
- Public Folder Management

Follow the steps below to grant permission to user account.

- Open <https://outlook.office365.com/ecp>
- Login to the **Exchange admin center** as an account administrator.

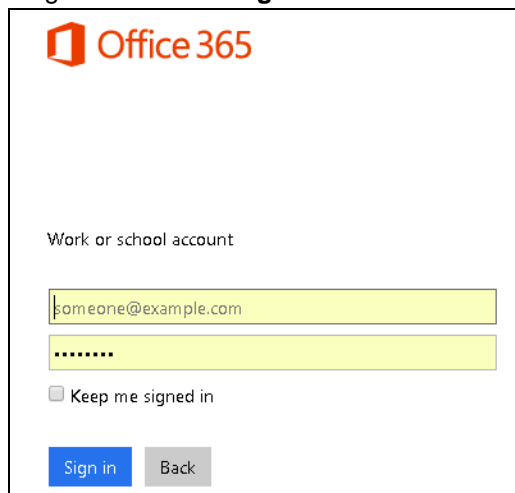

- Select the **permissions** menu on the left, then double click on **Discovery Management** or **Public Folder Management** on the right.

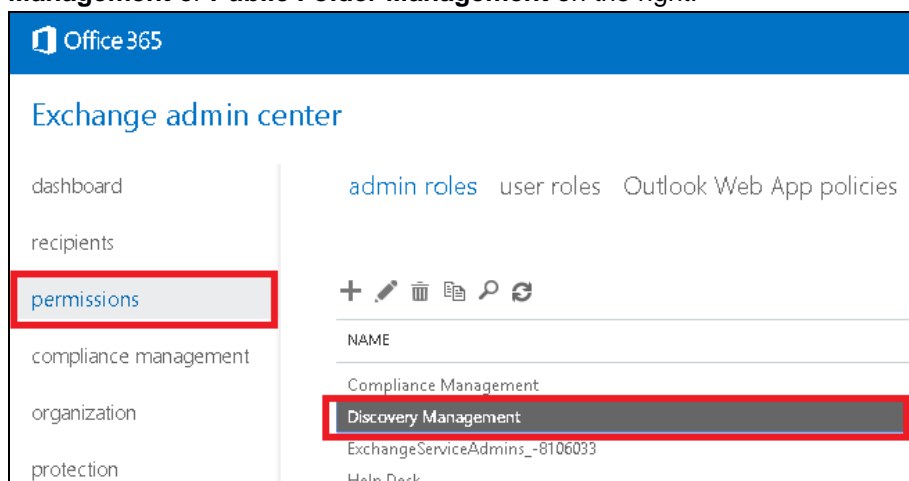

NAME
Compliance Management
Discovery Management
ExchangeServiceAdmins_-8106033
Help Desk

- iv. You can now add users to this group. Click the **+** icon under the **Members** section.

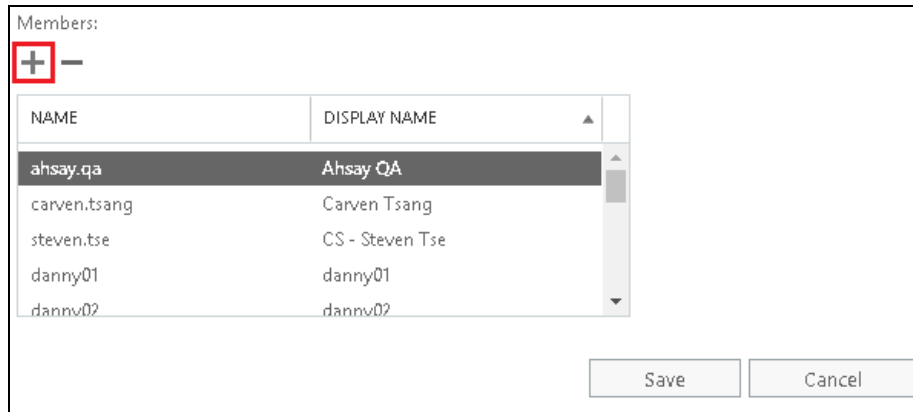

- v. Look for the username(s) of the account that you would like to add permission for, then click **add** > **OK** to add the corresponding user(s) to the permission group.

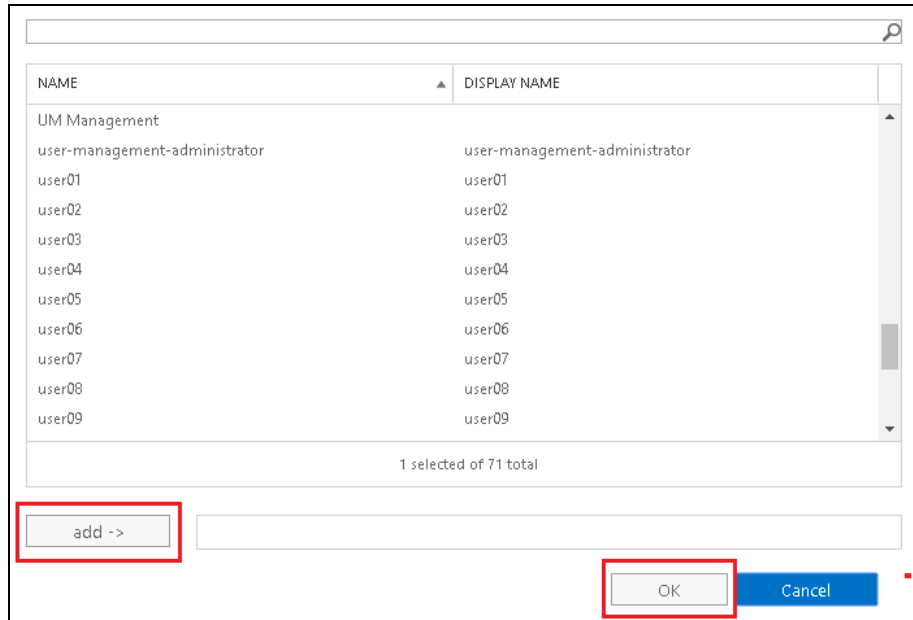

- vi. Click **Save** to confirm and exit the setting.

▶ **Granting Permission for Application Impersonation**

This permission allows users under the **Members** section of the **Discovery Management** group (refer to the previous section for setup) to back up and/or restore mailbox item(s) not only for their own account, but also accounts of other users in the same **Members** section. To grant permission for this feature, you have to add the **Application Impersonation** role by following the steps below.

- i. Open <https://outlook.office365.com/ecp>

- ii. Login to the **Exchange admin center** as an account administrator.

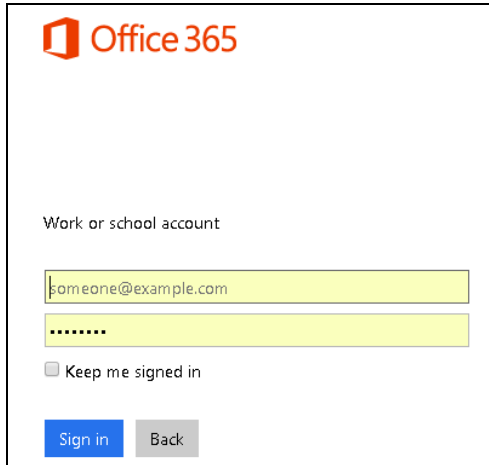

The image shows the Office 365 login page. At the top left is the Office 365 logo. Below it, the text "Work or school account" is displayed. There are two input fields: the first contains the email address "someone@example.com" and the second contains a masked password "*****". Below the password field is a checkbox labeled "Keep me signed in". At the bottom, there are two buttons: a blue "Sign in" button and a grey "Back" button.

- iii. Select the **permissions** menu on the left, then double click on **Discovery Management** on the right.

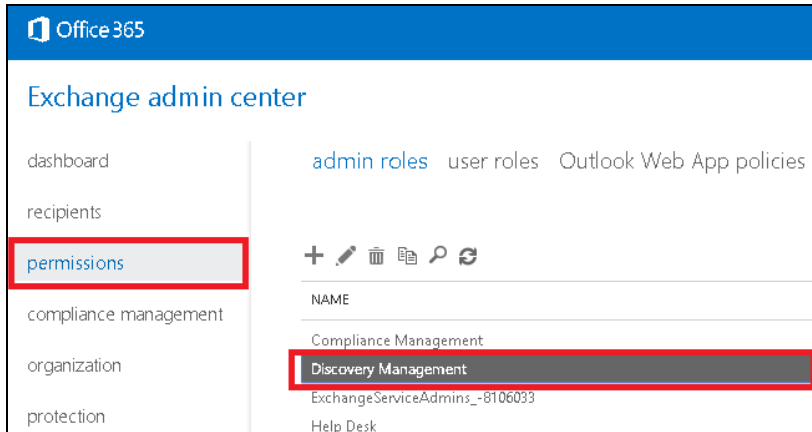

The image shows the Exchange admin center interface. The top navigation bar is blue with the Office 365 logo and the text "Exchange admin center". Below the navigation bar, there are several menu items on the left: "dashboard", "recipients", "permissions" (highlighted with a red box), "compliance management", "organization", and "protection". On the right side, there are links for "admin roles", "user roles", and "Outlook Web App policies". Below these links, there are icons for adding, editing, deleting, and refreshing. A table with the header "NAME" is displayed, containing the following entries: "Compliance Management", "Discovery Management" (highlighted with a red box), "ExchangeServiceAdmins_-8106033", and "Help Desk".

- iv. Click the **+** icon under the **Role** section.



The image shows the "Roles" section in the Exchange admin center. At the top, the text "Roles:" is displayed. Below it, there are two icons: a plus sign (+) and a minus sign (-), both highlighted with a red box. Below the icons, there is a table with the header "NAME" and a list of roles. The first two roles are "Legal Hold" and "Legal Hold". The third role is partially visible and contains a GUID: "CNF5ab72bb4a-10a3-4aed-99af-d10d422660b5".

- v. Select the **ApplicationImpersonation** role, then click the **add** button. Click **OK** afterward.

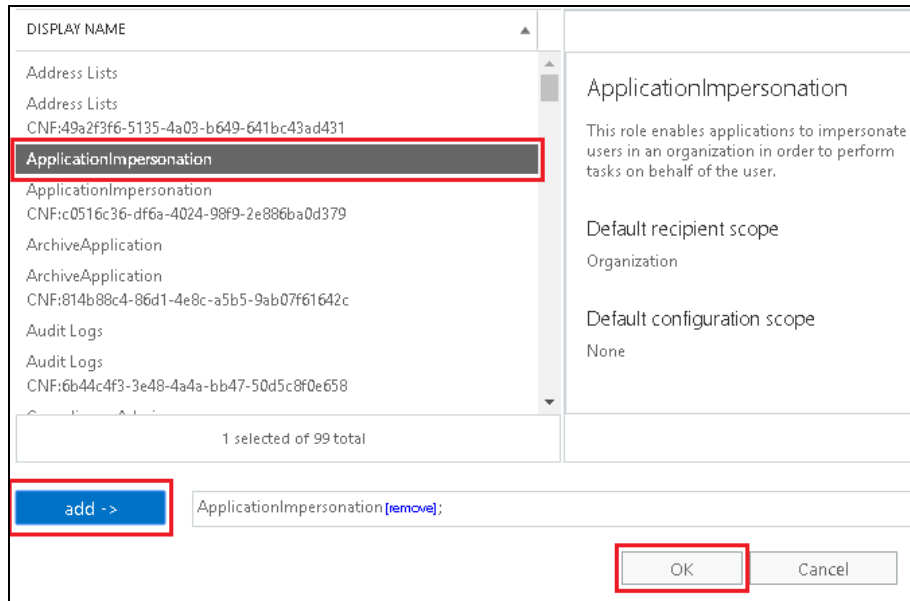

- vi. Click **Save** to confirm and exit the setting.

Supported Source

Below is the supported mailbox type of Office 365 Exchange Online Backup.

Mailbox Level			
Item	Supported?	Item	Supported?
User mailbox	✓	Room Mailbox	✓
Public Folder	✓	Equipment Mailbox	✓
Public Folder Mailbox	✓	Shared Mailbox	✓

Below is the items that you can backup or restore from an Office 365 Exchange Online backup set.

Folder Level			
Item	Supported?	Item	Supported?
Inbox	✓	RSS Feeds	✓
Drafts	✓	Junk Email	✓
Sent Items	✓	Tasks	✓
Deleted Items	✓	Calendar	✓

Archive	✓	Contacts	✓
Notes	✓		

Limitation

❶ Supports Backup up to 2 accounts

Each AhsayACB backup user account supports backup of a maximum of **TWO** Office 365 Exchange Online personal accounts.

Consider using AhsayOBM instead if you wish to back up for more than two Office 365 Exchange Online accounts. Contact your backup service provider for further details. Click here to read the [AhsayOBM v7 User Guide - Office365 Exchange Online Backup & Restore for Mac](#).

❷ Restore Only to Same Account

It is only possible to restore mailbox items to the **SAME** Office 365 Exchange Online mailbox account, no other restore destination is allowed.

If you wish to restore the backed up mailbox items to another user's mailbox under the same Office 365 Exchange Online account, consider using AhsayOBM instead. Click here to read the [AhsayOBM v7 User Guide - Office365 Exchange Online Backup & Restore for Mac](#).

Best Practices and Recommendations

The following are some best practices or recommendations we strongly recommend you to follow before you start any Office 365 Exchange Online backup and restore.

❶ Temporary Directory Folder Location (For backup and restore running on AhsayACB only)

Temporary directory folder is used by AhsayACB for storing backup set index files and any incremental or differential backup files generated during a backup job. To ensure optimal backup/restoration performance, it is recommended that the temporary directory folder is set to a local drive with sufficient free disk space.

❷ Performance Recommendations

Consider the following best practices for optimized performance of the backup operations:

- ❶ Enable schedule backup jobs when system activity is low to achieve the best possible performance.
- ❷ Perform test restores periodically to ensure your backup is set up and performed properly. Performing recovery test can also help identify potential issues or gaps in your recovery plan. It's important that you do not try to make the test easier, as the objective of a successful test is not to demonstrate that everything is flawless. There might be flaws identified in the plan throughout the test and it is important to identify those flaws.

❸ Individual Mail Object Size

Office 365 Exchange Online service has set a size limit for individual mail object to be uploaded. Considering the size of the mail object may become larger as a result of the

transcoding process when it is being sent out, we strongly recommend you to keep individual mail object no larger than **80MB** if you definitely want it to be backed up.

▶ **Set Backup Destination**

After creating the backup set in **Run on Client** mode on AhsayCBS user web console, please remember to set the backup destination for the backup set in AhsayACB.

▶ **Backup Destination**

To provide maximum data protection and flexible restore options, it is recommended to configure:

- ◉ At least one offsite or cloud destination
- ◉ At least one local destination for fast recovery

▶ **Login AhsayACB**

After modifying the backup schedule setting or Continuous Backup setting of the **Run on Client** backup set on AhsayCBS user web console, please remember to login to the AhsayACB client once to synchronize the changes immediately.

3 Login to AhsayACB / AhsayCBS User Web Console

Login to AhsayACB

1. Double-click the **AhsayACB** icon to launch the application.



2. Enter the **Login name** and **Password** of your AhsayACB account. Click **Show advanced option** to configure the **Backup Server** and **Proxy** details if necessary.

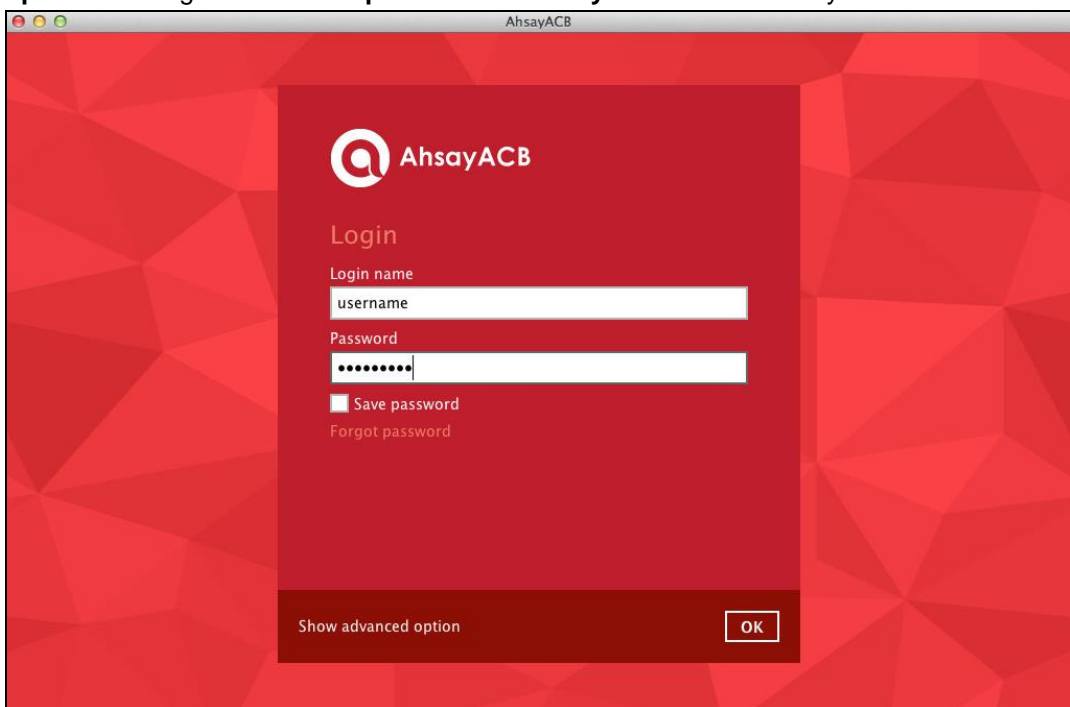

3. Click **OK** afterward to login to AhsayACB.

Login to AhsayCBS User Web Console

1. Login to the AhsayCBS web console at https://backup_server_hostname:port

Note: Contact your service provider for the URL to connect to the web console if necessary.

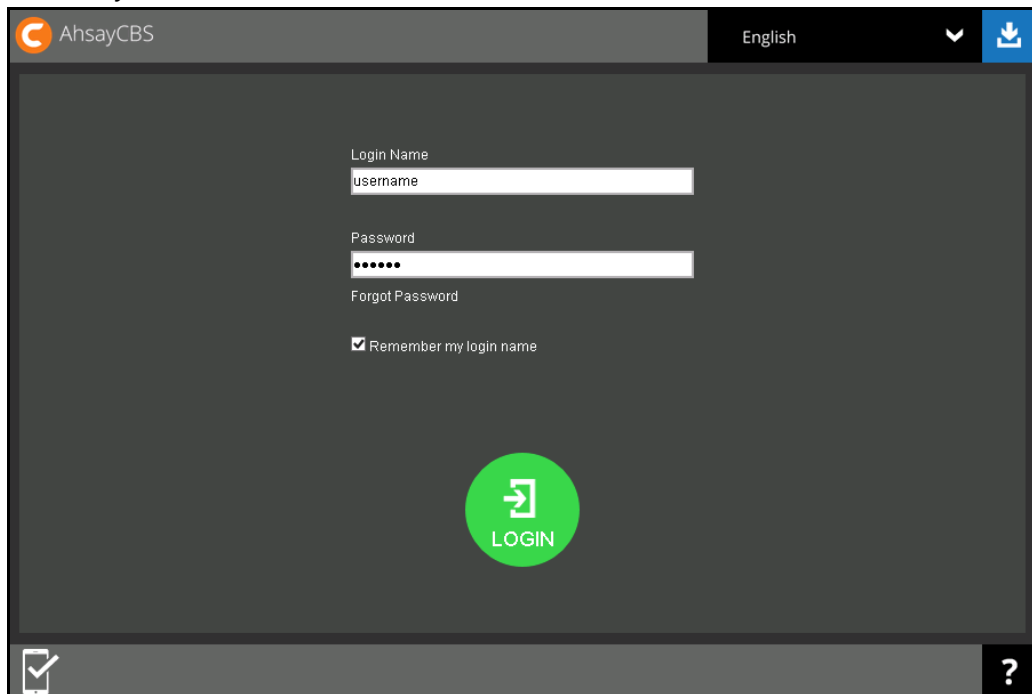

The screenshot shows the AhsayCBS login web console interface. At the top left, there is the AhsayCBS logo. At the top right, there is a language dropdown menu set to "English" and a download icon. The main area contains a login form with the following fields and options:

- Login Name: A text input field containing the text "username".
- Password: A password input field with masked characters "*****".
- Forgot Password: A link below the password field.
- Remember my login name: A checked checkbox.
- LOGIN: A large green circular button with a white login icon and the text "LOGIN" below it.

At the bottom left, there is a checkmark icon, and at the bottom right, there is a question mark icon.

2. Enter the Login Name and Password of your AhsayACB account.
3. Click **LOGIN** afterward to login to the web console.

4 Creating an Office 365 Exchange Online Backup Set

Creating a Backup Set on AhsayACB

1. In the AhsayACB main interface, click **Backup Sets**.



2. Click the "+" icon next to **Add new backup set**.
3. Enter a **Name** for your backup set and select **Office 365 Exchange Online Backup** as the **Backup set type**.

The "Create Backup Set" form. The title "Create Backup Set" is at the top in blue. Below it is a "Name" field with the placeholder text "Office 365 Backup Set Name". Underneath is a "Backup set type" dropdown menu. The dropdown is open, showing four options: "File Backup" (with a folder icon), "File Backup" (with a folder icon), "Cloud File Backup" (with a cloud icon), and "Office 365 Exchange Online Backup" (with an Office 365 icon). The "Office 365 Exchange Online Backup" option is highlighted in blue.

4. Enter the user name and password of your Office 365 Exchange Online account, then press **Test** to validate the account.

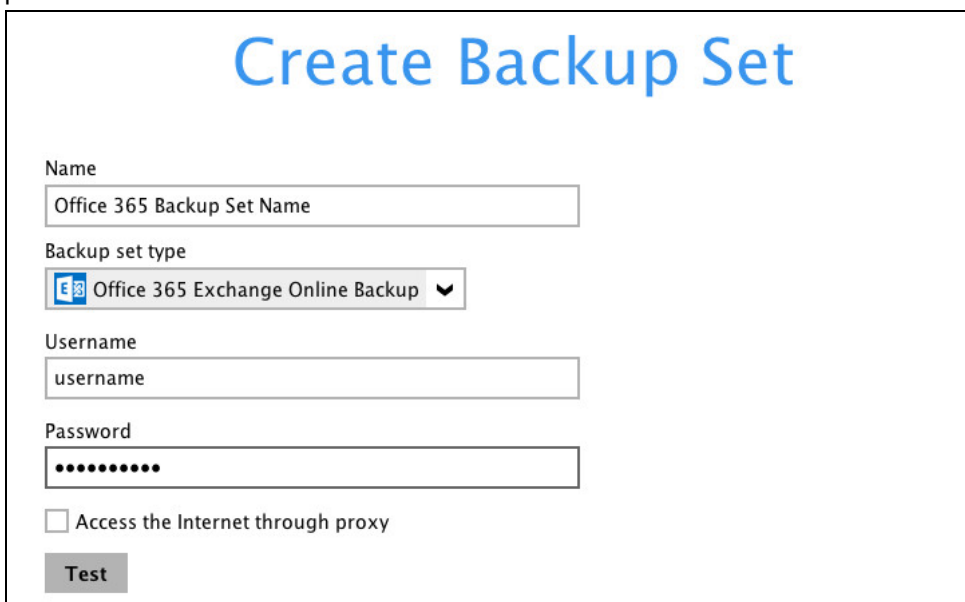
The "Create Backup Set" form. The title "Create Backup Set" is at the top in blue. Below it is a "Name" field with the placeholder text "Office 365 Backup Set Name". Underneath is a "Backup set type" dropdown menu with "Office 365 Exchange Online Backup" selected. Below that are "Username" and "Password" fields. The "Username" field contains the placeholder text "username". The "Password" field contains a series of dots. At the bottom, there is a checkbox labeled "Access the Internet through proxy" which is unchecked, and a "Test" button.

Test completed successfully shows when the validation is successful. Press **Next** to proceed to the next step.

Password

•••••

Access the Internet through proxy

✓ Test completed successfully

5. In the **Backup Source** menu, select the desired user account and content folder for backup.

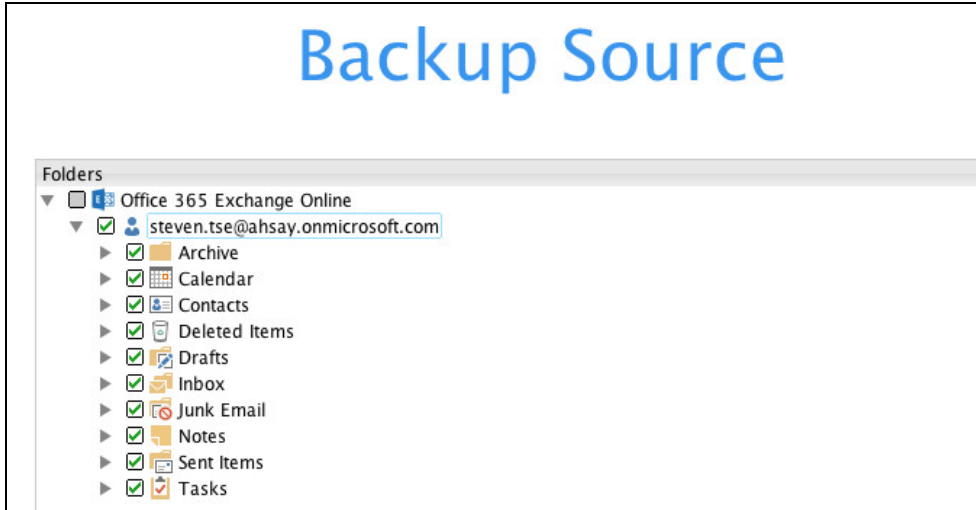

Enable the **Show mails** checkbox at the bottom left corner if you would like to choose individual mail object for backup.

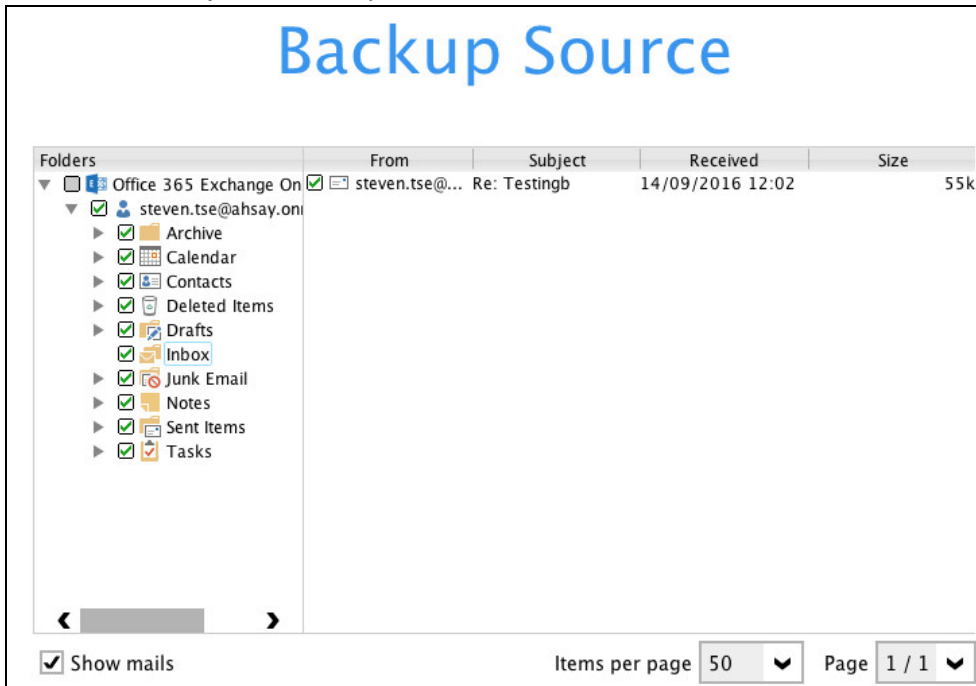

6. In the **Schedule** menu, configure a backup schedule for backup job to run automatically at your specified time interval. Slide the on/off button to turn on this feature, then click **Add new schedule** to add a new schedule, then click **Next** to proceed afterward.

Schedule

Run scheduled backup for this backup set

On

Existing schedules

Add new schedule

Configure the backup schedule settings on this page, then click **OK** when you are done with the settings, then click **Next** to proceed.

New Backup Schedule

Name

Type

Start backup at

 :

Stop

Run Retention Policy after backup

7. In the Destination menu, select a backup destination where the backup data will be stored. Click the “+” icon next to **Add new storage destination / destination pool**.

Destination

Backup mode

Existing storage destinations

Add new storage destination / destination pool

Note

For more details on Backup Destination, refer to the following KB article for details:
<https://forum.ahsay.com/viewtopic.php?f=186&t=14049>

8. Select the storage type.

- **Single storage** destination – the entire backup will be uploaded to one single destination you selected under the **Destination storage** drop-down list. By default, the destination storage is selected as **CBS**.

New Storage Destination / Destination Pool

Name

Type
 Single storage destination
 Destination pool

Destination storage

- **Destination pool** – the backup will be spread over on the destinations you have selected. Enter a **Name** for the destination pool and then click **Add new storage destination to the pool** to select the desired storage destinations.

New Storage Destination / Destination Pool

Name

Type
 Single storage destination
 Destination pool

Add the cloud (e.g. Google Drive or Dropbox) or local storage that you would like to pool together for backup. You can always add more storage to this pool in the future.

Existing storage destinations in the pool
 Add new storage destination to the pool

^ v

You can choose a storage combination of the Local/Mapped drive/Removable Drive, Cloud storage or FTP. Click **OK** to proceed when you are done with the settings.

- If you have chosen the Local/Mapped Drive/Removable Drive option, click **Change** to browse to a directory path where backup data will be stored, then click **Test** to validate the path. **Test completed successfully** shows when the validation is done.

New Storage Destination For The Pool

Name

Destination storage

Local path

- If you have chosen the Cloud Storage, click **Test** to log in to the corresponding cloud storage service.

New Storage Destination For The Pool

Name

Destination storage

[Sign up for Google Drive](#)

- If you have chosen the FTP as the destination, enter the the Host, Username and Password details.

New Storage Destination For The Pool

Name

Destination storage

Host Port

Username

Password

(optional) FTP directory to store backup data (default to ~/Ahsay)

9. You can add multiple storage destinations. The backup data will be uploaded to all the destinations you have selected in the order you added them. Press the icon to alter the order. Click **Next** to proceed when you are done with the selection.

Destination

Backup mode

Existing storage destinations

- AhsayCBS
- DestinationPool-1

10. In the Encryption window, the default **Encrypt Backup Data** option is enabled with an encryption key preset by the system which provides the most secure protection.



The screenshot shows the 'Encryption' window with the following settings:

- Encrypt Backup Data:** On (checked)
- Encryption Type:** Default (selected from a dropdown menu that also shows 'User password' and 'Custom')

You can choose from one of the following three Encryption Type options:

- **Default** – an encryption key with 44 alpha numeric characters will be randomly generated by the system
- **User password** – the encryption key will be the same as the login password of your AhsayACB at the time when this backup set is created. Please be reminded that if you change the AhsayACB login password later, the encryption keys of the backup sets previously created with this encryption type will remain unchanged.
- **Custom** – you can customize your encryption key, where you can set your own algorithm, encryption key, method and key length.

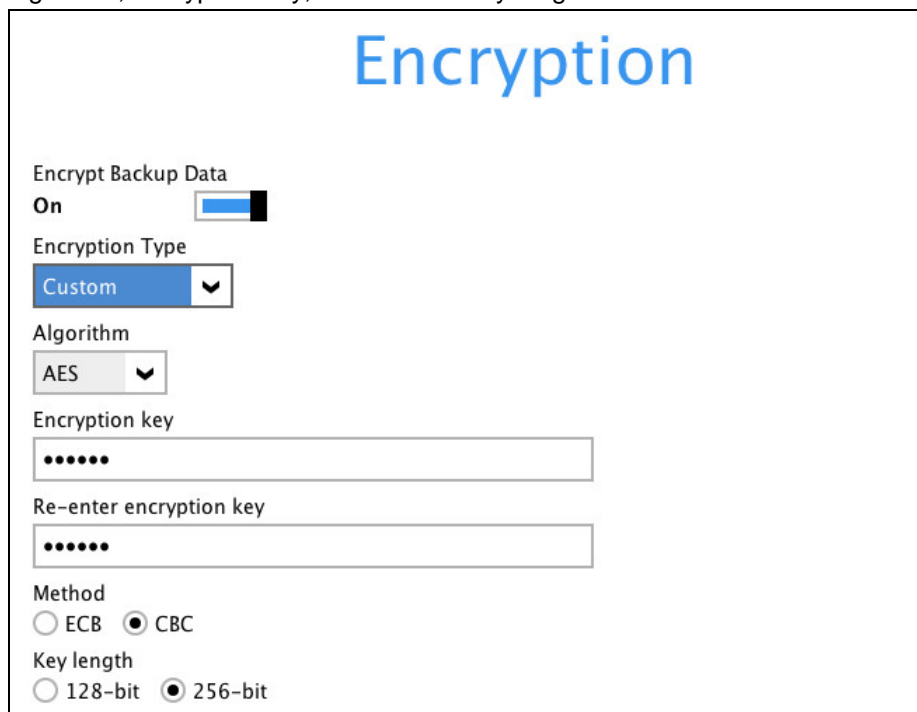

The screenshot shows the 'Encryption' window with the following settings:

- Encrypt Backup Data:** On (checked)
- Encryption Type:** Custom (selected from a dropdown menu)
- Algorithm:** AES (selected from a dropdown menu)
- Encryption key:** [Redacted with dots]
- Re-enter encryption key:** [Redacted with dots]
- Method:** ECB CBC
- Key length:** 128-bit 256-bit

Note: For best practice on managing your encryption key, refer to the following KB article.
<https://forum.ahsay.com/viewtopic.php?f=169&t=14090>

Click **Next** when you are done setting.

11. If you have enabled the Encryption Key feature in the previous step, the following pop-up window shows, no matter which encryption type you have selected.

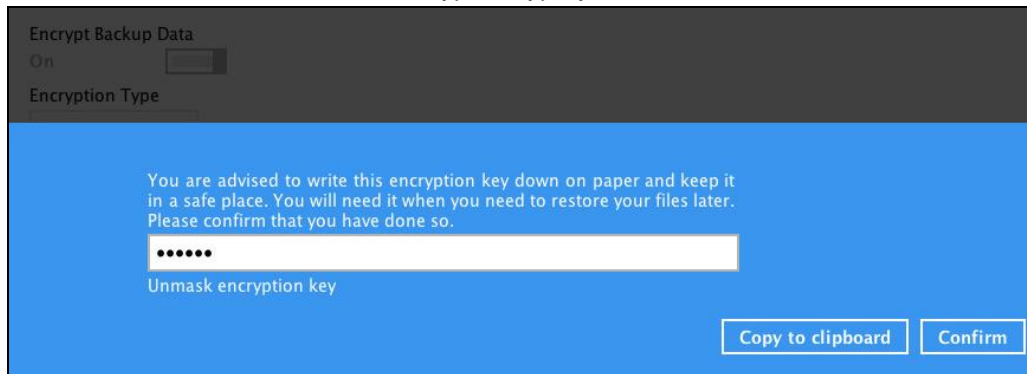

The pop-up window has the following three options to choose from:

- **Unmask encryption key** – The encryption key is masked by default. Click this option to show the encryption key.

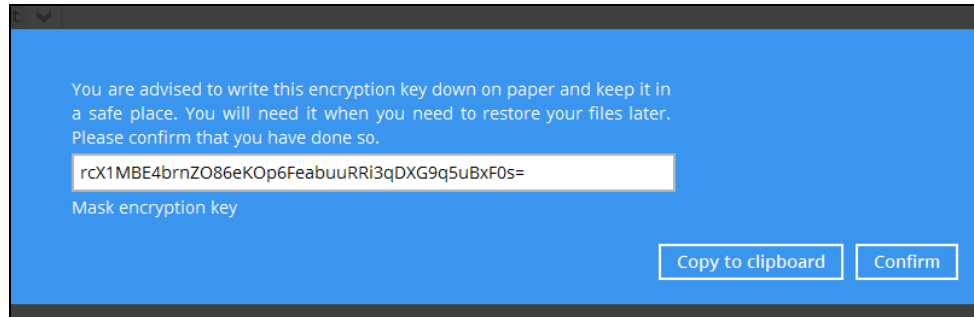

- **Copy to clipboard** – Click to copy the encryption key, then you can paste it in another location of your choice.
 - **Confirm** – Click to exit this pop-up window and proceed to the next step.
12. The following screen is displayed when the new Office 365 Exchange Online backup set is created successfully.

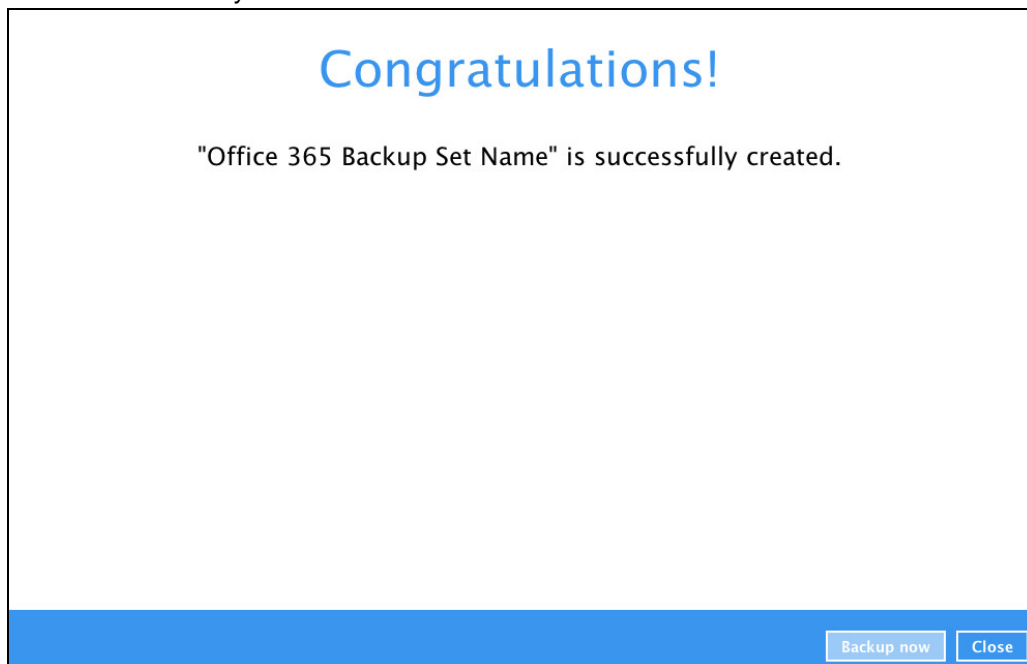

Create a Backup Set on User Web Console

1. Log in to the User Web Console according to the instructions in [Login to User Web Console](#).
2. Click the User icon on the User Web Console landing page.

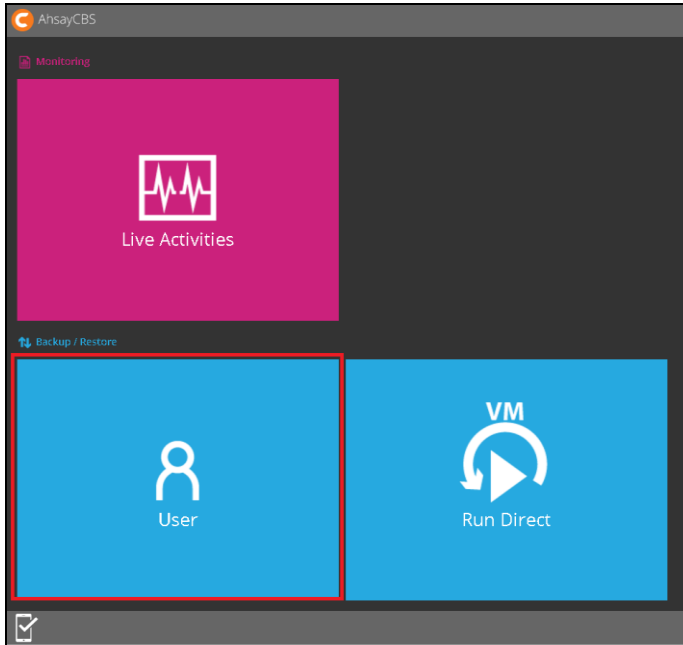

3. On the **Backup Set** menu, click the + icon highlighted to create a backup set.

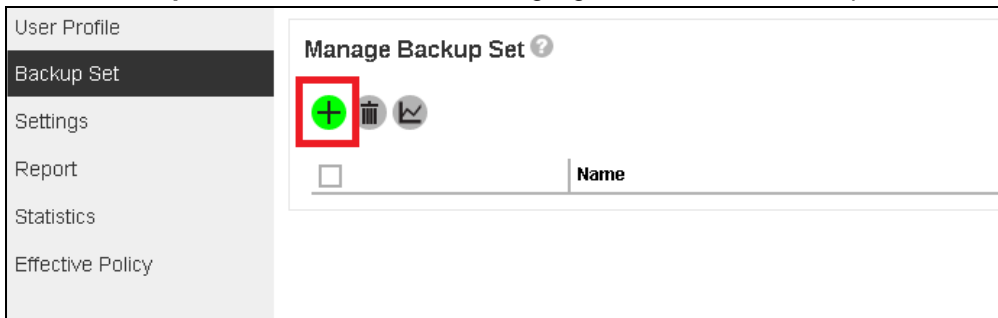

4. Select the type as **Office 365 Exchange Online Backup**, then name the backup set.

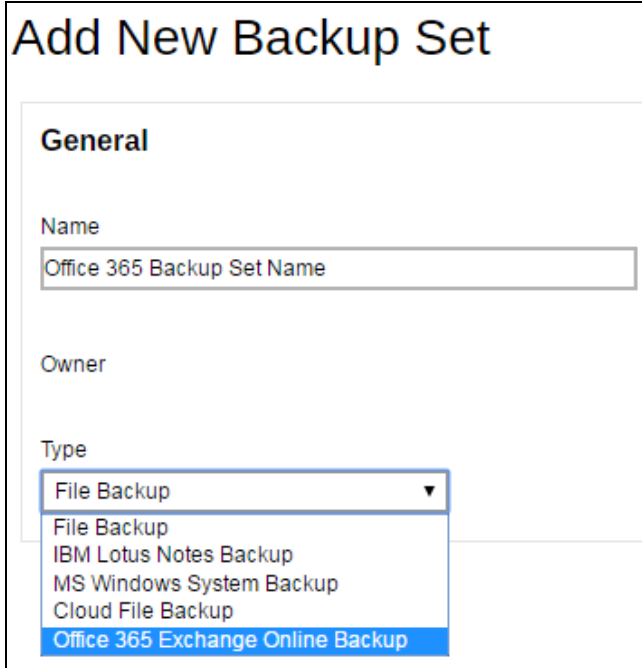

Add New Backup Set

General

Name
Office 365 Backup Set Name

Owner

Type
File Backup
File Backup
IBM Lotus Notes Backup
MS Windows System Backup
Cloud File Backup
Office 365 Exchange Online Backup

5. On the same menu under **Run on**, select **Server** to create a run on server (agentless backup) backup set or **Client** to create a run on client (agent-based backup) backup set.
- **Server** - If you choose to run the backup set on the CBS server, you won't be able to back up, restore or manage your backups on the AhsayACB once the backup set is created.
 - **Client** - If you choose to run the backup set on the AhsayACB, you won't be able to back up, restore or manage your backups on the AhsayCBS Web Management Console once the backup is created.

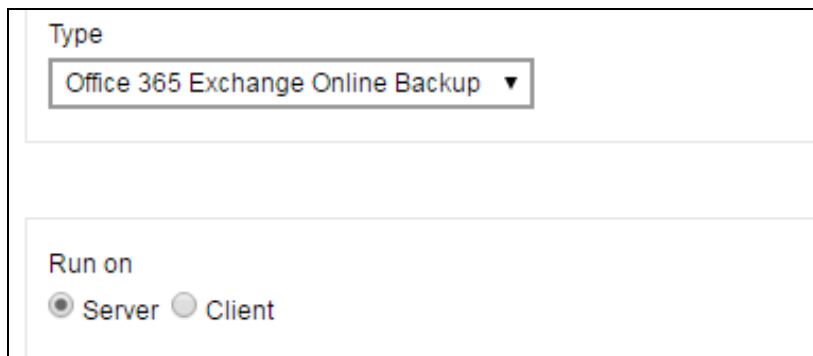

Type
Office 365 Exchange Online Backup

Run on
 Server Client

Notes

1. This setting **CANNOT** be altered once the backup set is created. If you wish to change the backup method later, you will have to create a new backup set and start over the configurations again.
2. For backup sets created in **Run on Server** backup type, the backup destination is restricted to AhsayCBS by default and cannot be altered. If you wish to back up to other destinations, backup sets should be created in **Run on Client** backup type instead.

- Enter the user name and password of your Office 365 Exchange Online account, then press **Test** to verify the account.

The screenshot shows a configuration form for Office 365 Exchange Online Backup. At the top, there is a dropdown menu labeled 'Type' with 'Office 365 Exchange Online Backup' selected. Below this is a section for 'Run on' with radio buttons for 'Server' (selected) and 'Client'. There are two input fields: 'Username' containing 'username' and 'Password' containing a masked password '*****'. A checkbox labeled 'Access the Internet through Proxy' is unchecked. At the bottom left is a 'Test' button, and at the bottom right is a link that says 'Sign up for Office 365 Exchange Online Backup'.

- Press the  icon at the bottom right corner to proceed when you are done settings.

- Select the **Backup Source** in this menu. Click on the folder or individual file you would like to back up.

The screenshot shows the 'Add New Backup Set' interface. At the top, it says 'Add New Backup Set'. Below that is a section titled 'Backup Source' with a 'Refresh' button. On the left, there is a tree view of backup sources under 'Office 365 Exchange Online' for the account 'steven.tse@ahsay.onmicrosoft.com'. The tree includes folders like Archive, Calendar, Contacts, Deleted Items, Drafts, Inbox, Junk Email, Notes, Sent Items, and Tasks. On the right, there is a table with columns 'From' and 'Subject'. The table contains one entry: a checked checkbox, 'steven.tse@ahsay.com' in the 'From' column, and 'Re: Testingb' in the 'Subject' column.

- Press the  icon at the bottom right corner to proceed when you are done with the selection.

- If you would like the backup set to run at a specified time interval of your choice, turn this feature on by sliding the on/off switch in the **Schedule** menu.

The screenshot shows the 'Add New Backup Set' interface, specifically the 'Schedule' menu. It features a toggle switch labeled 'Run scheduled backup for this backup set' which is currently turned on.

If you choose to turn this feature on, you may configure the following items.

- Name of the scheduled backup
- Backup schedule type
- Backup start time
- Run Retention Policy after backup

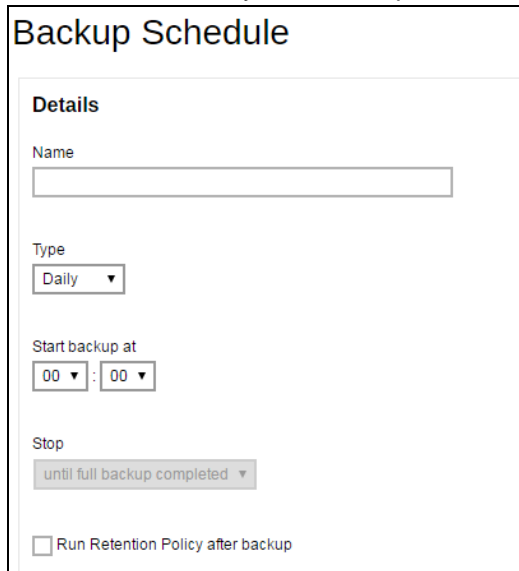

The screenshot shows a form titled "Backup Schedule" with a "Details" section. It includes a text input for "Name", a dropdown for "Type" set to "Daily", a time selector for "Start backup at" (00:00), a dropdown for "Stop" set to "until full backup completed", and a checkbox for "Run Retention Policy after backup".

Click the  icon at the bottom right corner to confirm the backup schedule once you finish setting.

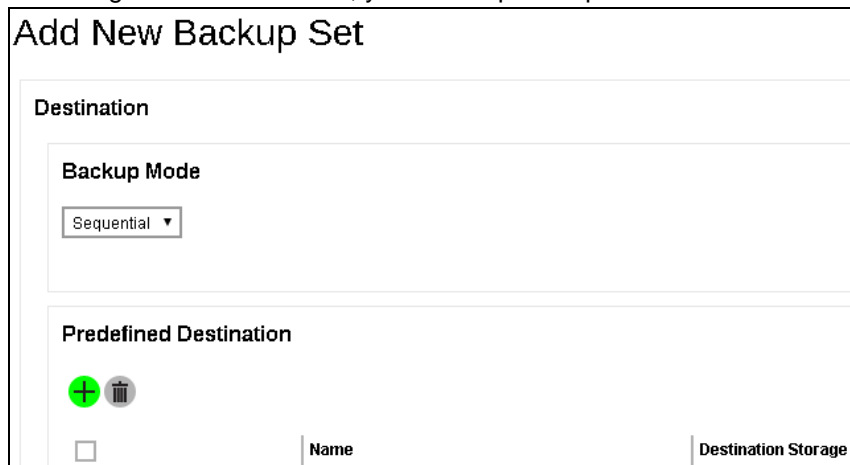

11. This step is only for user who has chosen to Run the backup set on **Client** in step 5.

If you have chosen to Run on **Server**, the backup destination is preset as the CBS and is not configurable. In that case, you can skip to step 12 now.



The screenshot shows a form titled "Add New Backup Set" with a "Destination" section. It includes a "Backup Mode" dropdown set to "Sequential" and a "Predefined Destination" section with a green plus icon and a trash icon. Below this is a table with columns for "Name" and "Destination Storage".

To define the backup destination, there are two options:

- In this menu, you can choose the Predefined Destination set by your backup service provider. Click the  icon under the **Predefined Destination** section to display the available destinations. Mark the checkbox of your desired destination, then click the  icon at the bottom right corner to confirm your selection.

Add Predefined Destination

Add predefined destination to this backup set below. If there are no predefined destinations created, you need to go to *AhsayCBS > Backup Server > Basic > Predefined

<input type="checkbox"/>	Name	Destination Storage	Info
<input checked="" type="checkbox"/>	MKT-Cloud-Storage		Google Accou
<input type="checkbox"/>	Dropbox-1		Dropbox Acco

Add New Backup Set

Destination

Backup Mode

Sequential ▾

Predefined Destination

+ -

<input type="checkbox"/>	Name	Destination Storage
<input type="checkbox"/>	MKT-Cloud-Storage	

- If you would like to choose other backup destination other than the Predefined Destination, proceed to the next step without making any setting here. You will have to complete this backup set creation first, then log in to the AhsayACB and configure the backup destination from there. For further details, refer to [Appendix A Setting Backup Destination on AhsayACB for Backup Created on User Web Console](#).

Press the icon at the bottom right corner to proceed when you are done with the setting.

12. By default, the **Encrypt Backup Data** option is enabled with the Encryption Type preset as **Default** which provides the most secure protection.

Add New Backup Set

Encryption

Encrypt Backup Data

Encryption Type

Default (Machine Generated Random) ▾

You can choose from one of the following three Encryption Type options:

- **Default (Machine Generated Random)** – an encryption key with 44 alpha numeric characters will be randomly generated by the system
- **User password** – the encryption key will be the same as the login password of your AhsayACB at the time when this backup set is created. Please be reminded that if you change the AhsayACB login password later, the encryption keys of the backup sets previously created with this encryption type will remain unchanged.

- **Custom** – you can customize your encryption key, where you can set your own algorithm, encryption key, method and key length.

Add New Backup Set

Encryption

Encrypt Backup Data

Encryption Type

Algorithm

Encrypting key

Re-type encrypting key

Method
 ECB CBC

Key length
 128-bit 256-bit

Click the green  icon at the bottom right corner to confirm the backup schedule once you finish setting.

13. Click the  icon at the bottom right corner to confirm creating this backup set.

5 Overview of Office 365 Exchange Online Backup Process

The following steps are performed during an Office 365 Exchange Online backup job:

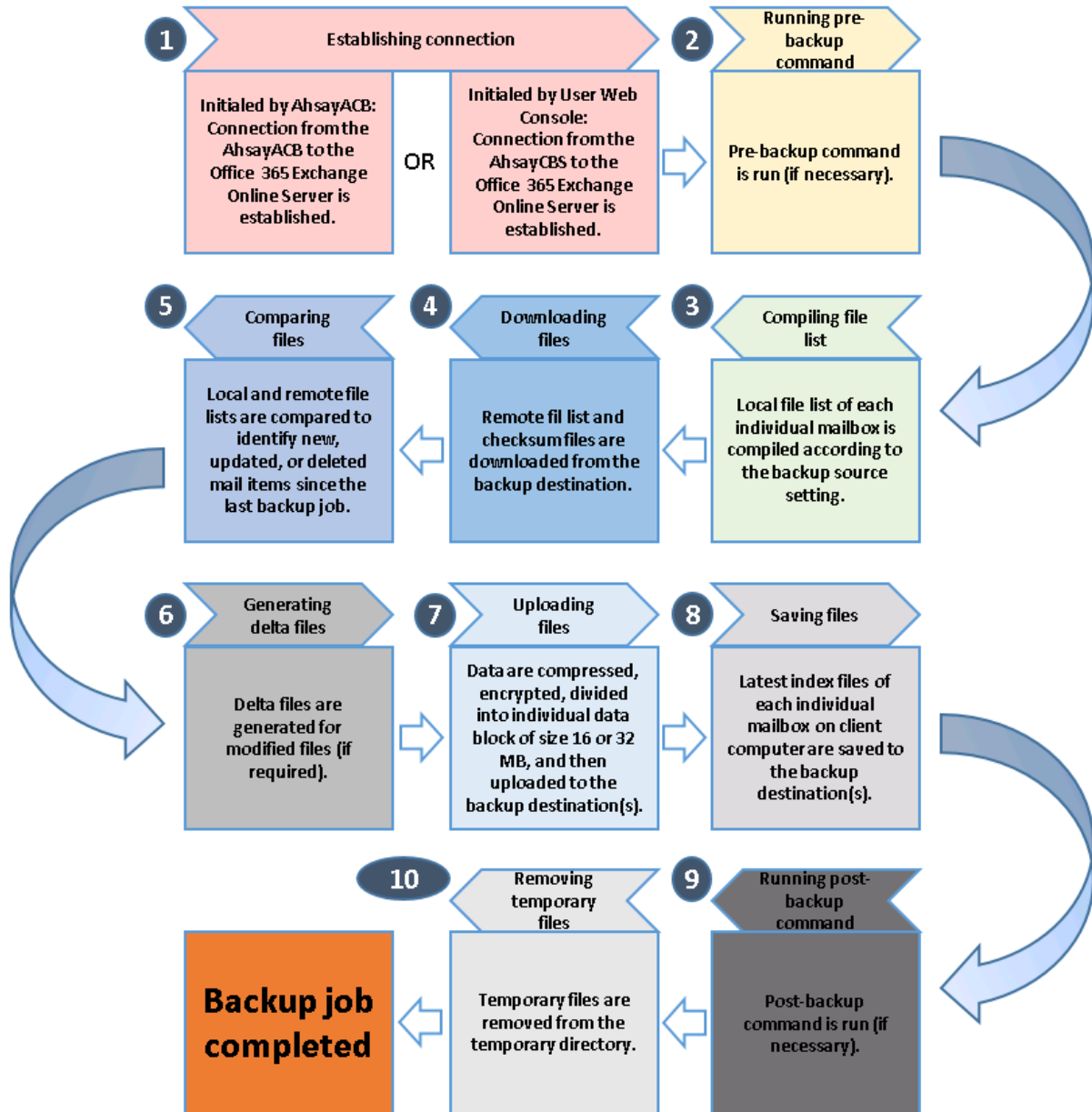

6 Running Backup Job

Start a Manual Backup in AhsayACB

1. Login to AhsayACB according to the instructions in [Login to AhsayACB](#).
2. Click the **Backup** icon on the main interface of AhsayACB.



3. Select the backup set which you would like to start a backup for.

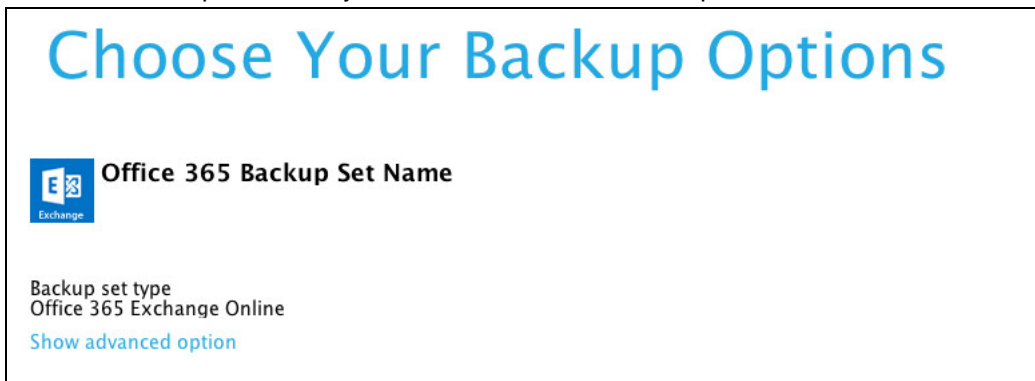

4. If you would like to modify the In-File Delta type, Destinations and Retention Policy Settings, click **Show advanced option**.
5. Click **Backup** to start the backup.

Start a Manual Backup on the User Web Console

1. Log in to the User Web Console according to the instructions in Login to User Web Console.
2. Click on the User icon.

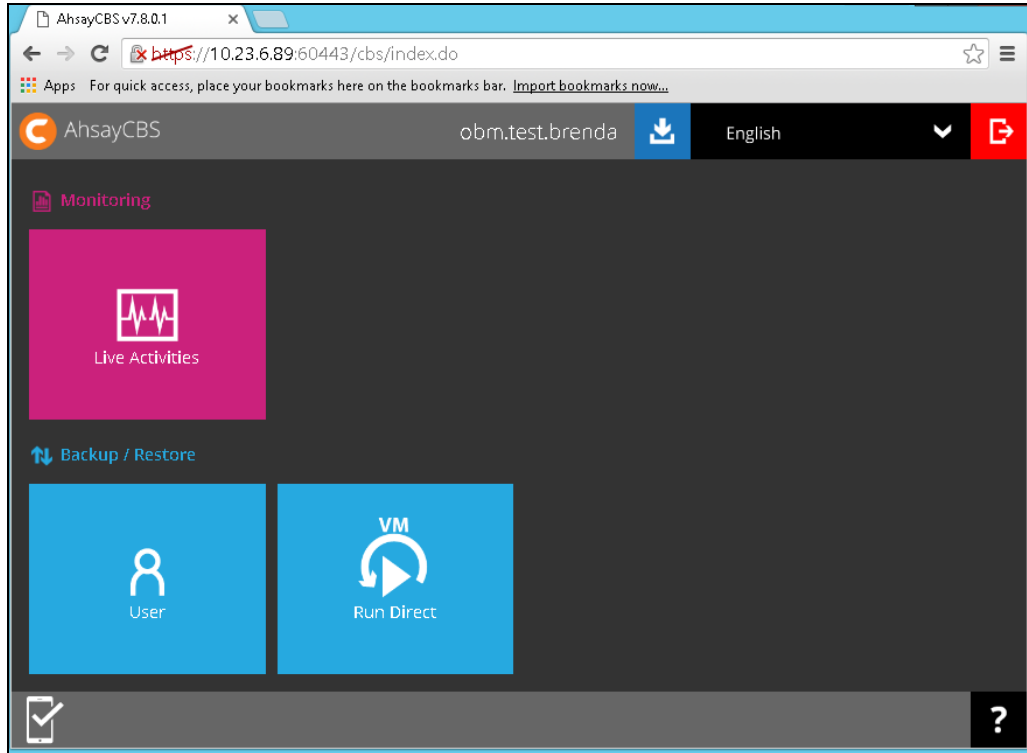

3. Under the **Backup Set > Manage Backup Set** menu, you should see the backup set you have created.

Manage Backup Set ?

+ 🗑️ 📄

<input type="checkbox"/>	Name	Type	Version	Execute Job
<input type="checkbox"/>	Office365-MyOwnMailbox		--	Backup ▼ Run
<input type="checkbox"/>	Office 365 Backup Set Name (Server)		--	Backup ▼ Run

4. Click the drop-down menu on the backup set that you would like to start a backup for. Select **Backup** and then click **Run**.

Name	Type	Version	Execute Job
Office365-MyOwnMailbox		--	Backup ▼ Run
Office 365 Backup Set Name (Server)		--	Backup ▼ Run
Office 365 Backup Set		--	Backup ▼ <ul style="list-style-type: none"> Backup Restore Data Integrity Check Space Freeing Up Delete Backup Data

5. Modify the **In-file Delta type** and **Retention Policy** settings if necessary.

Backup

In-File Delta type

Full



Differential

Incremental

Retention Policy

Run Retention Policy after backup

6. Click the  icon at the bottom right corner to start the backup.
7. You will see the status showing **Backup is Running** when the backup is in progress.

Type	Version	Execute Job
	--	Backup <input type="button" value="Run"/>
	--	Backup is Running <input type="button" value="Stop"/>

Configure Backup Schedule for Automated Backup

Setting up on AhsayACB

1. Click the **Backup Sets** icon on the AhsayACB main interface.

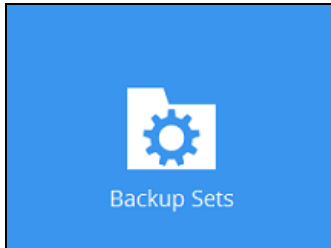

2. Select the backup set that you want to create a backup schedule for.

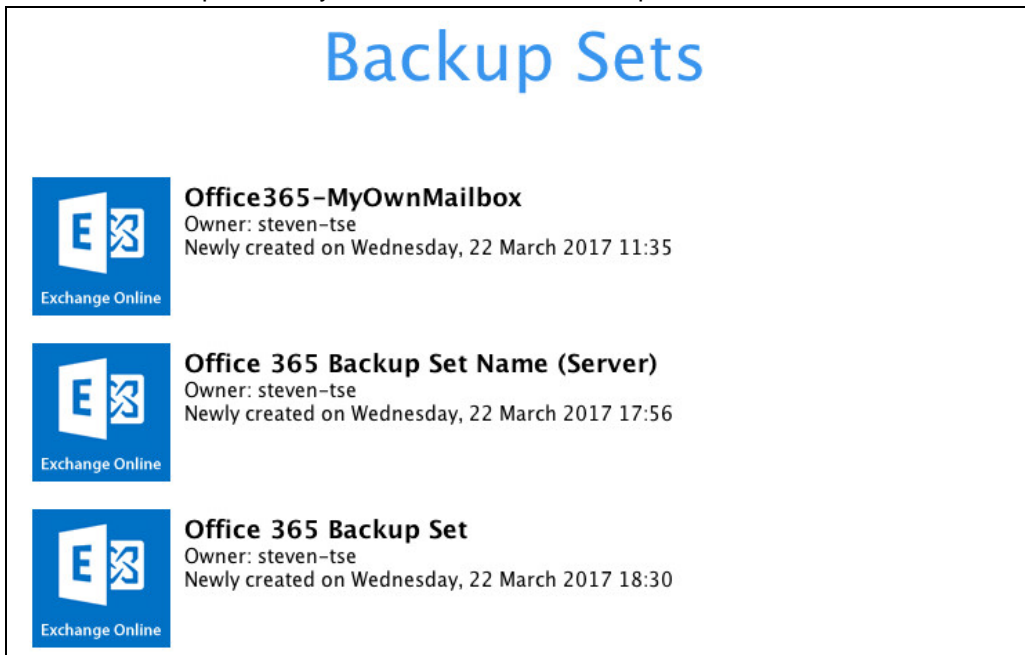

3. Click on the **Backup Schedule** tab.

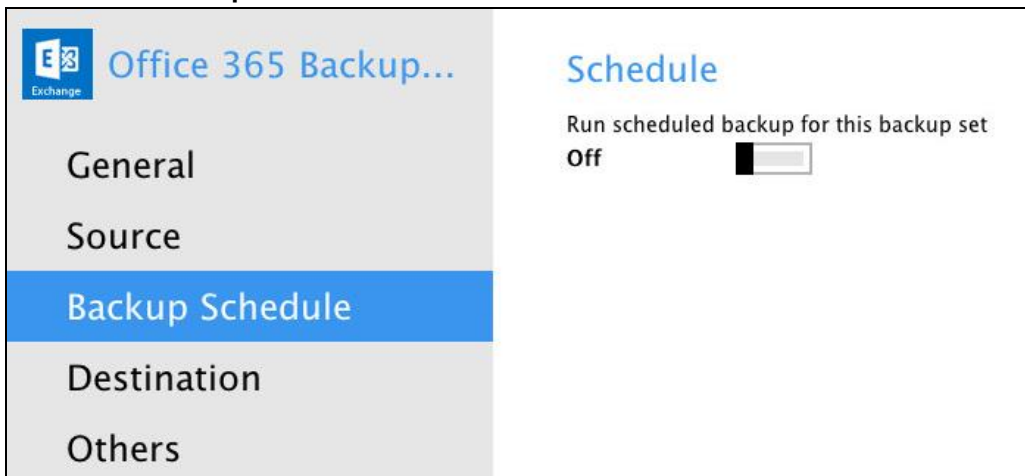

4. Turn on the backup schedule by switching the “Run scheduled backup for this backup set” feature to **On**, then click the + icon next to **Add new schedule**.

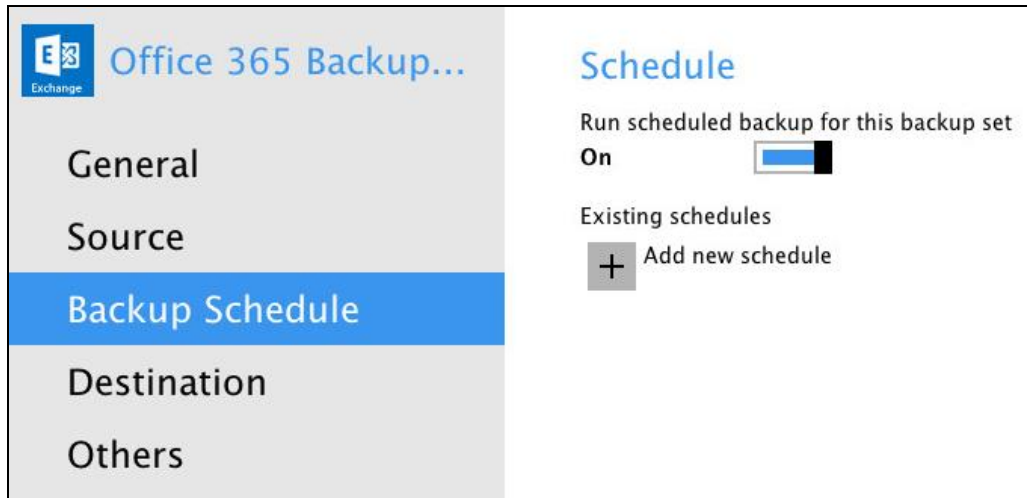

5. Configure the backup schedule settings on this page, then click **OK** when you are done with the settings.

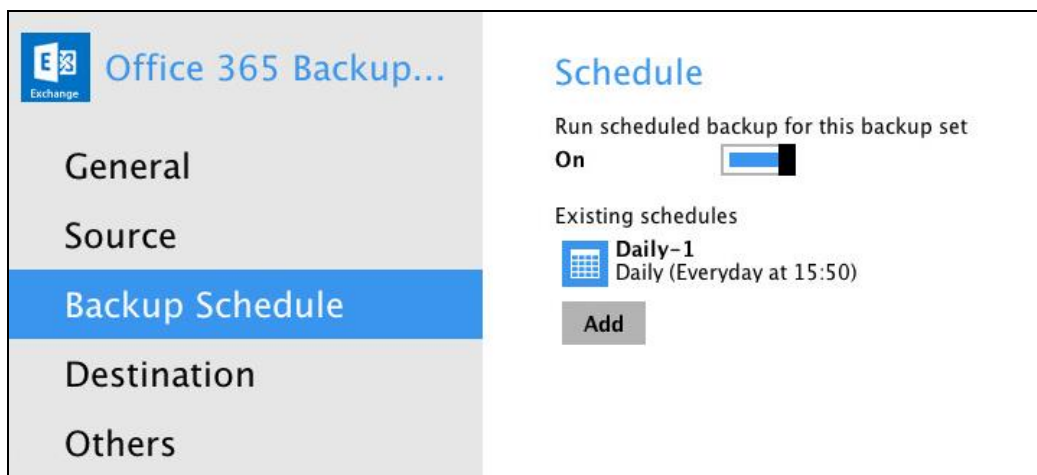
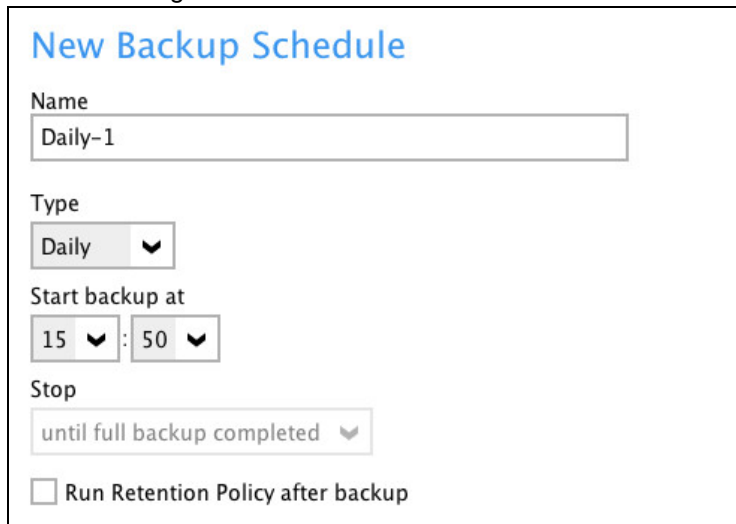

6. Click **Save** to confirm the settings and exit the **Backup Schedule** menu.

Setting on User Web Console

1. Click on the **User** icon on the main page of the User Web Console.

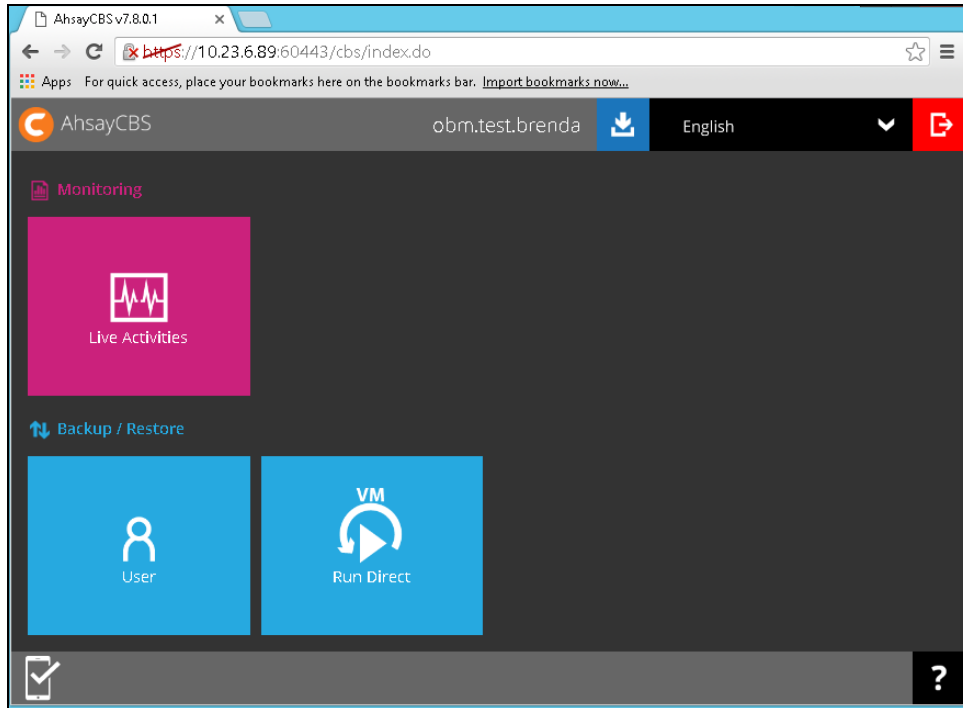

2. Click on the backup set which you would like to create a scheduled backup for under the **Backup Set** menu.

Manage Backup Set ?

<input type="checkbox"/>	Name	Type	Version	Execute Job
<input type="checkbox"/>	Office365-MyOwnMailbox		--	Backup <input type="button" value="Run"/>
<input type="checkbox"/>	Office 365 Backup Set Name (Server)		--	Backup <input type="button" value="Run"/>

3. Go to the **Backup Schedule** menu, slide the on/off switch at the right to turn this feature on.

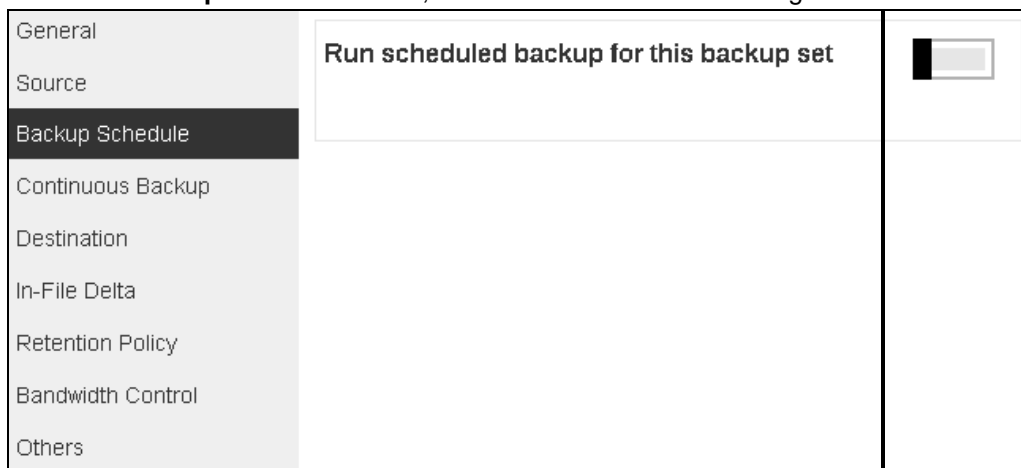

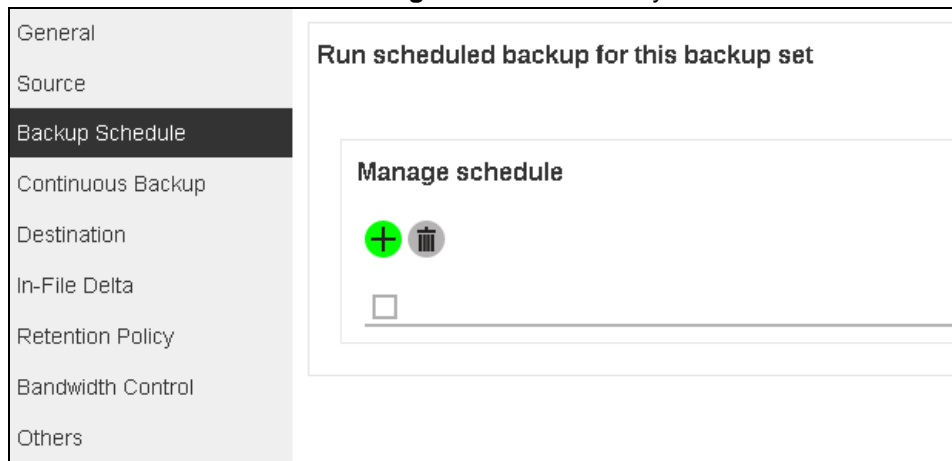

4. Click the  icon under the **Manage schedule** to add your desired schedule.



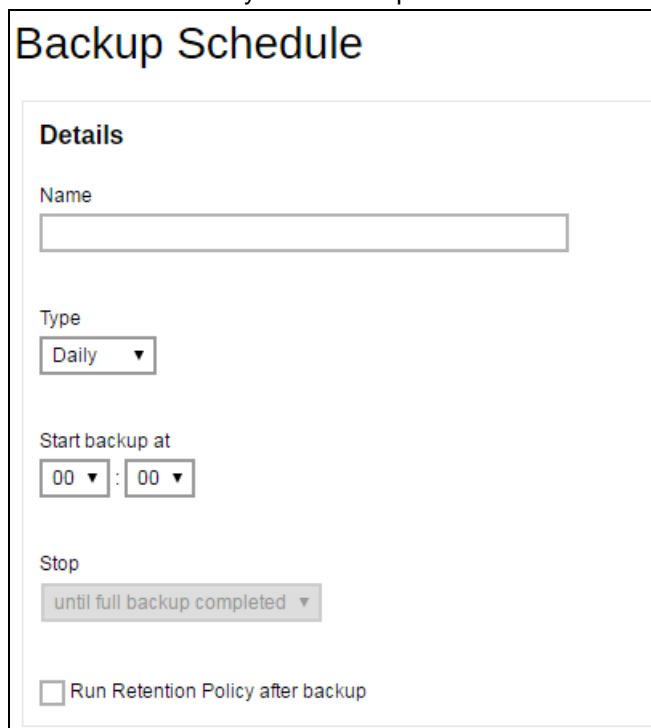

5. You may configure the following items for the schedule.

- Name of the scheduled backup
- Backup schedule type
- Backup start time
- Run Retention Policy after backup

A screenshot of a 'Backup Schedule' configuration form. The title is 'Backup Schedule'. Under the 'Details' section, there are several fields: a text input for 'Name', a dropdown menu for 'Type' with 'Daily' selected, a time selection for 'Start backup at' (00 : 00), a dropdown for 'Stop' with 'until full backup completed' selected, and a checkbox for 'Run Retention Policy after backup' which is currently unchecked.

Click the  icon at the bottom right corner to confirm the backup schedule once you finish setting.

6. Click the  icon and then the  icon to confirm the setting.

7 Restoring Office 365 Exchange Online Backup Set

Follow the instructions below to restore the Office 365 Exchange Online backup to the original Office 365 account.

Restore Backup with AhsayACB

1. Login to AhsayACB according to the instructions in [Login to AhsayACB](#).
2. Click the **Restore** icon on the main interface of AhsayACB.

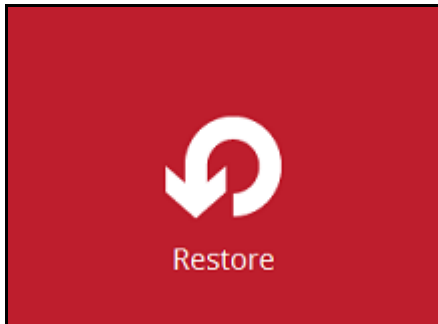

3. Select the backup set that you would like to restore.

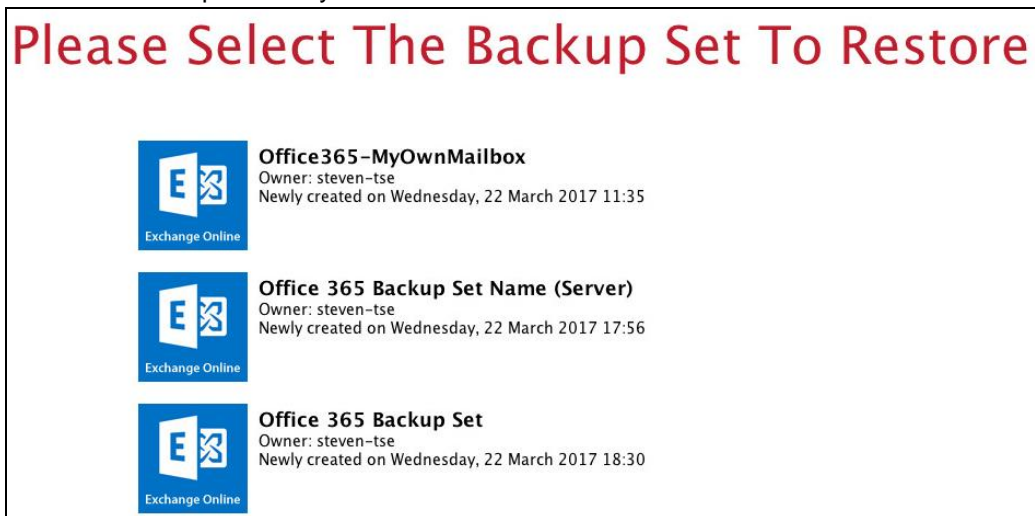

4. Select the backup destination that you would like to restore mail items to.



- Select the item(s) you would like to restore. You can also choose to restore backed up file from a specific backup job of your choice using the **Select what to restore** drop-down menu at the top. Click **Next** to proceed when you are done with the selection.

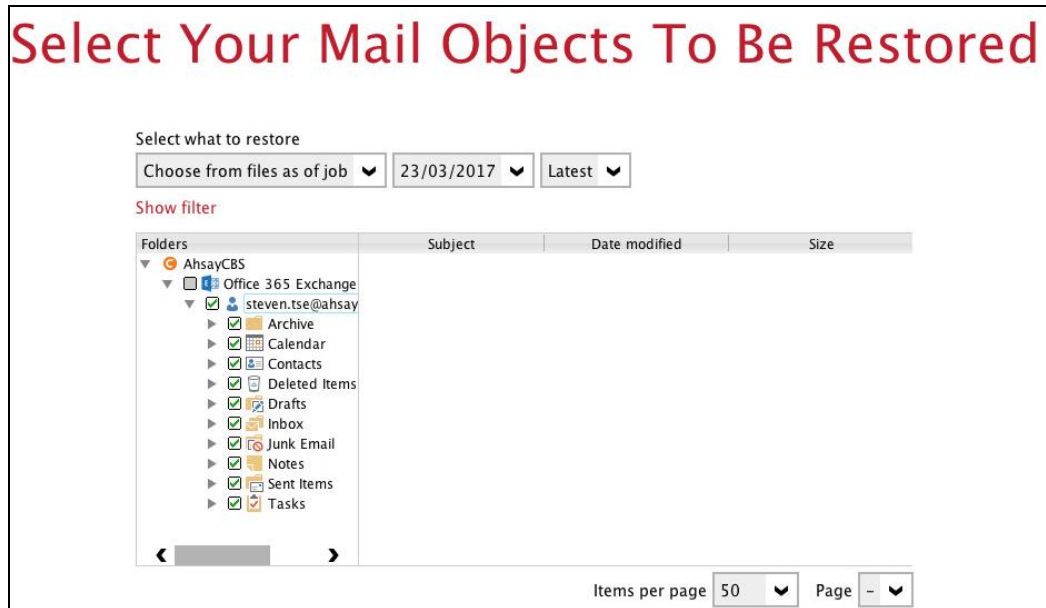

- The backed up mailbox items can only be restored to the original mailbox, no other restore location is available. Click **Next** when you see this screen to proceed.



- Select the temporary directory for storing temporary files, such as delta files when they are being merged, click **Restore** to start the restoration.



Restore Backup with User Web Console

1. Log in to the User Web Console according to the instructions in [Login to User Web Console](#).
2. Click on the **User** icon.

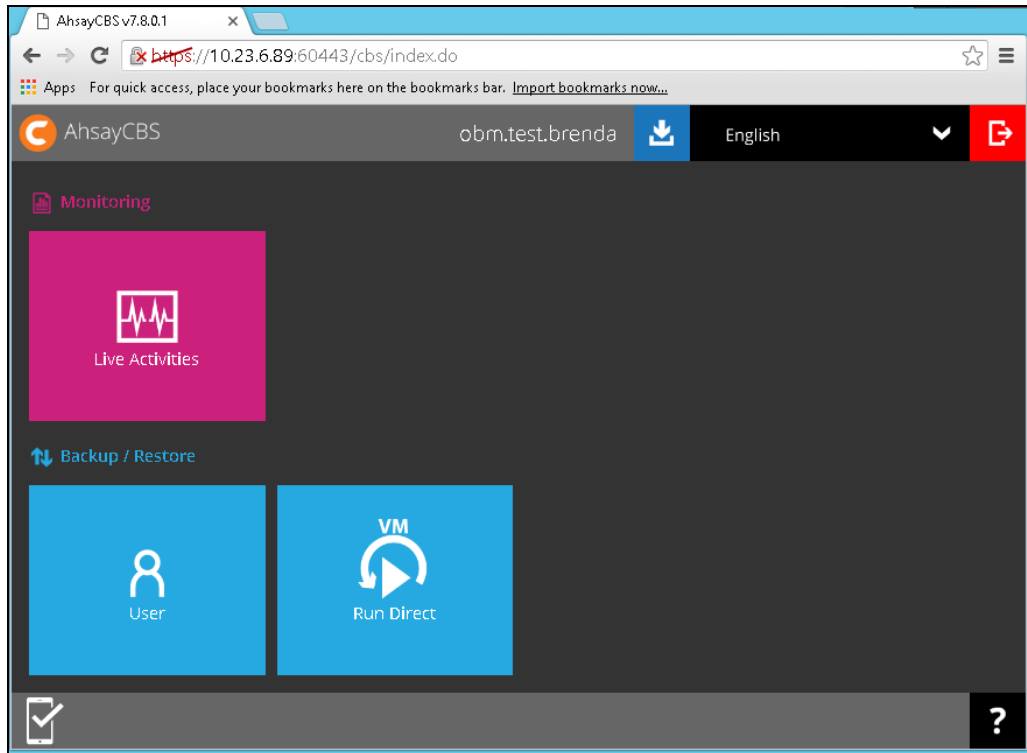



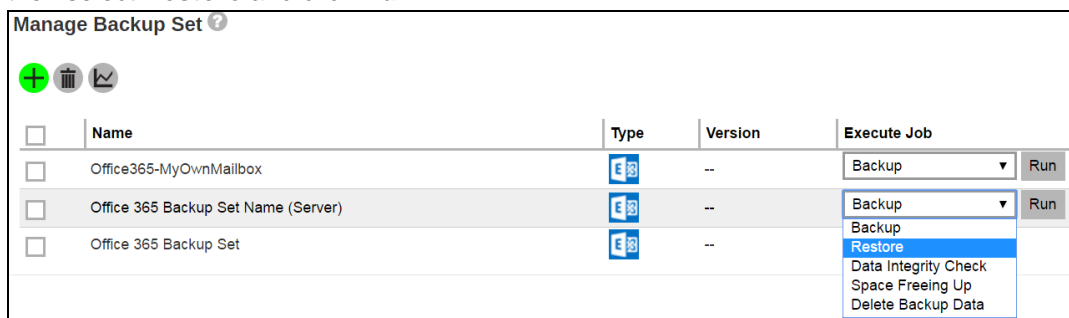

3. You should see the backup set you would like to restore under **Backup Set > Manage Backup Set**. Click on the drop-down menu on the backup set you would like to restore, then select **Restore** and click **Run**.



4. Select the mail object that you would like to restore. You can also choose to restore backed up mail objects from a specific backup job of your choice using the **Select What to Restore** drop-down menu.



5. Click the  icon to proceed when you are done with the selection.
6. The backed up mailbox items can only be restored to the original mailbox, no other restore location is available.
7. Click the  icon to start the restoration.
8. You will see the status showing **Restore is Running** when the restore is in progress.

Type	Version	Execute Job
	--	Backup <input type="button" value="Run"/>
	--	Restore is Running

8 Contacting Ahsay

Technical Assistance

To contact Ahsay support representatives for technical assistance, visit the following website:

<https://www.ahsay.com/jsp/en/contact/kbQuestion.jsp>

Also use the Ahsay Knowledge Base for resource such as Hardware Compatibility List, Software Compatibility List, and other product information:

<https://forum.ahsay.com>

Documentation

Documentations for all Ahsay products are available at:

https://www.ahsay.com/jsp/en/home/index.jsp?pageContentKey=ahsay_downloads_documentation_guides

You can send us suggestions for improvements or report on issues in the documentation, by contacting us at:

<https://www.ahsay.com/jsp/en/contact/kbQuestion.jsp>

Please specify the specific document title as well as the change required/suggestion when contacting us.

Appendix

Appendix A Setting Backup Destination on AhsayACB for Backup Set Created on User Web Console

You need to read the instructions below only if you:

- Have created a backup set on AhsayCBS User Web Console; **AND**
- Selected the backup set to Run on Client; **AND**
- Have not selected any Predefined Destination in the backup creation process on the User Web Console

-OR-

Have selected a Predefined Destination in the backup creation process on User Web Console but wish to add additional backup destination other than the predefined destination.

1. Log in to AhsayACB according to the instructions in [Login to AhsayACB](#).
2. In the AhsayACB main interface, click **Backup Sets**.



3. Click the backup set which you wish to add backup destination to.

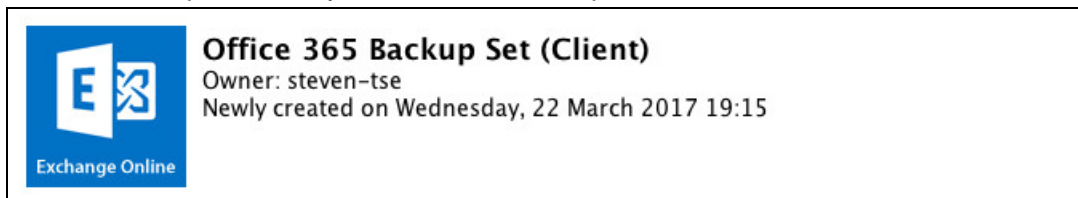

4. Click the **Destination** menu on the left side, then click the **Add** button on the right to add backup destination.

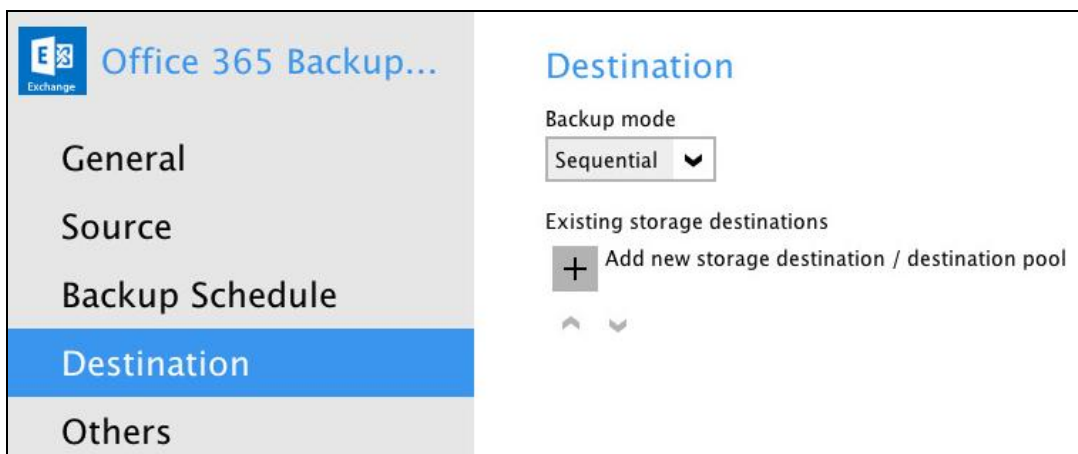

5. Select the storage type.

- **Single storage destination** – the entire backup will be uploaded to one single destination you selected under the **Destination storage** drop-down list. By default, the destination storage is selected as **CBS**.

New Storage Destination / Destination Pool

Name

Type
 Single storage destination
 Destination pool

Destination storage

- **Destination pool** – the backup will be spread over on the destinations you have selected. Enter a **Name** for the destination pool and then click **Add new storage destination to the pool** to select the desired storage destinations.

New Storage Destination / Destination Pool

Name

Type
 Single storage destination
 Destination pool

Add the cloud (e.g. Google Drive or Dropbox) or local storage that you would like to pool together for backup. You can always add more storage to this pool in the future.

Existing storage destinations in the pool
 Add new storage destination to the pool

^ v

You can choose a storage combination of the Local/Mapped drive/Removable Drive, Cloud storage or FTP. Click **OK** to proceed when you are done with the settings.

- If you have chosen the Local/Mapped Drive/Removable Drive option, click **Change** to browse to a directory path where backup data will be stored, then click **Test** to validate the path. **Test completed successfully** shows when the validation is done.

New Storage Destination For The Pool

Name

Destination storage

Local path

- If you have chosen the Cloud Storage, click **Test** to log in to the corresponding cloud storage service.

New Storage Destination For The Pool

Name

Destination storage

[Sign up for Google Drive](#)

- If you have chosen the FTP as the destination, enter the the Host, Username and Password details.

New Storage Destination For The Pool

Name

Destination storage



Host Port

Username

Password

(optional) FTP directory to store backup data (default to ~/Ahsay)

Connect with SSL/TLS (explicit only)

6. You can add multiple storage destinations. The backup data will be uploaded to all the destinations you have selected in the order you added them. Press the   icon to alter the order. Click **Next** to proceed when you are done with the selection.

Destination

Backup mode

Existing storage destinations



DestinationPool-1



AhsayCBS

